



This is a digital copy of a book that was preserved for generations on library shelves before it was carefully scanned by Google as part of a project to make the world's books discoverable online.

It has survived long enough for the copyright to expire and the book to enter the public domain. A public domain book is one that was never subject to copyright or whose legal copyright term has expired. Whether a book is in the public domain may vary country to country. Public domain books are our gateways to the past, representing a wealth of history, culture and knowledge that's often difficult to discover.

Marks, notations and other marginalia present in the original volume will appear in this file - a reminder of this book's long journey from the publisher to a library and finally to you.

Usage guidelines

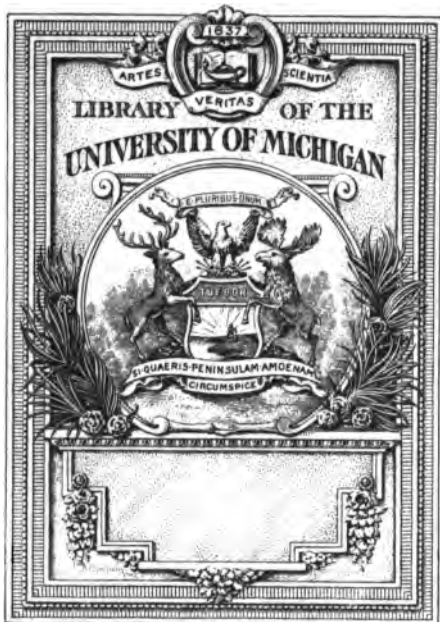
Google is proud to partner with libraries to digitize public domain materials and make them widely accessible. Public domain books belong to the public and we are merely their custodians. Nevertheless, this work is expensive, so in order to keep providing this resource, we have taken steps to prevent abuse by commercial parties, including placing technical restrictions on automated querying.

We also ask that you:

- + *Make non-commercial use of the files* We designed Google Book Search for use by individuals, and we request that you use these files for personal, non-commercial purposes.
- + *Refrain from automated querying* Do not send automated queries of any sort to Google's system: If you are conducting research on machine translation, optical character recognition or other areas where access to a large amount of text is helpful, please contact us. We encourage the use of public domain materials for these purposes and may be able to help.
- + *Maintain attribution* The Google "watermark" you see on each file is essential for informing people about this project and helping them find additional materials through Google Book Search. Please do not remove it.
- + *Keep it legal* Whatever your use, remember that you are responsible for ensuring that what you are doing is legal. Do not assume that just because we believe a book is in the public domain for users in the United States, that the work is also in the public domain for users in other countries. Whether a book is still in copyright varies from country to country, and we can't offer guidance on whether any specific use of any specific book is allowed. Please do not assume that a book's appearance in Google Book Search means it can be used in any manner anywhere in the world. Copyright infringement liability can be quite severe.

About Google Book Search

Google's mission is to organize the world's information and to make it universally accessible and useful. Google Book Search helps readers discover the world's books while helping authors and publishers reach new audiences. You can search through the full text of this book on the web at <http://books.google.com/>



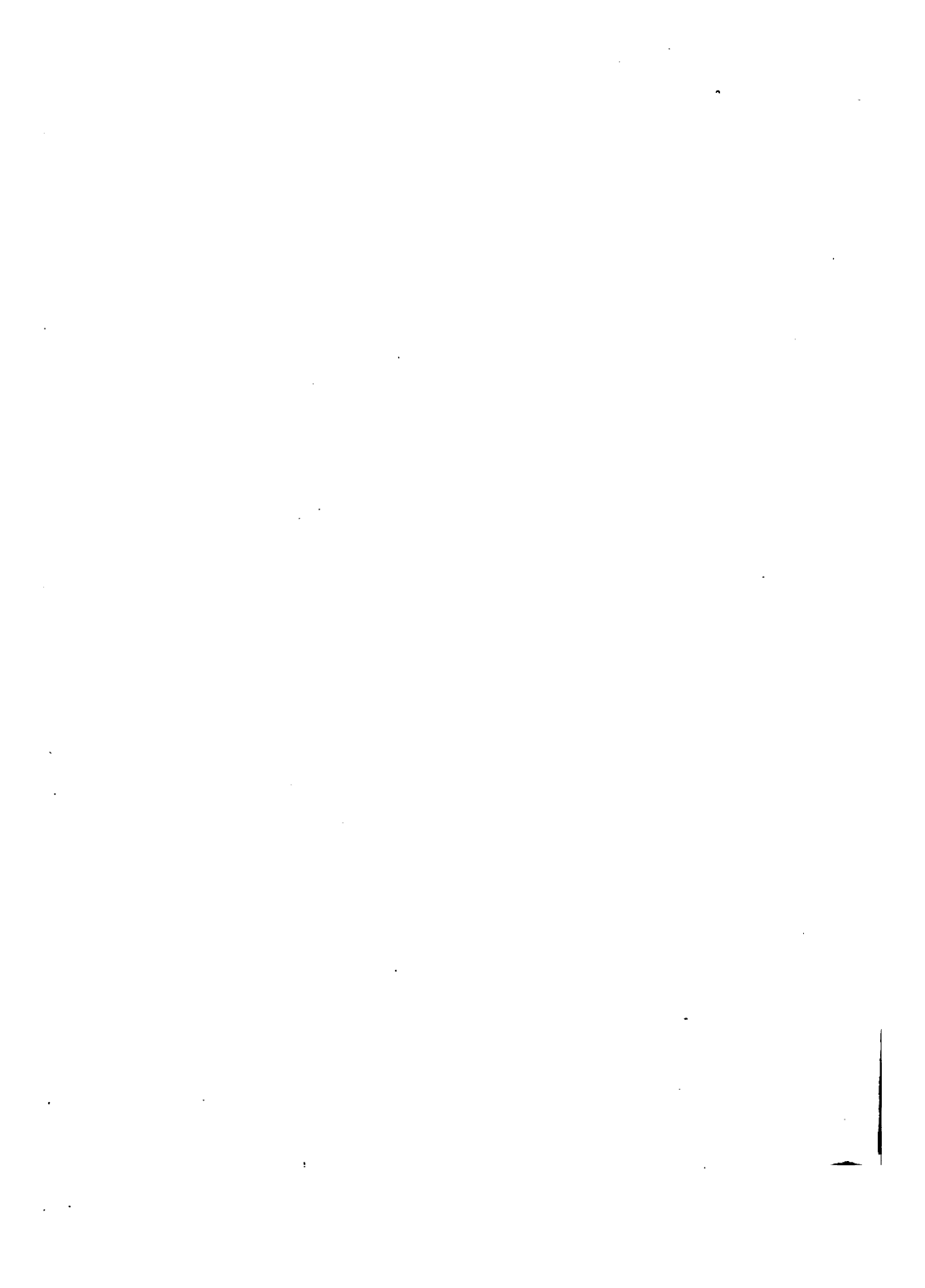
Arthur J. J. J.

Astronomical
Observatory

TS
543

U6
M37







D. H. CHURCH.

THE EVOLUTION
OF
AUTOMATIC MACHINERY

101485

AS APPLIED TO

THE MANUFACTURE OF WATCHES

AT WALTHAM, MASS., BY

THE AMERICAN WALTHAM WATCH COMPANY

*Edward
Walter*
BY E. A. MARSH

WITH HALF-TONE ILLUSTRATIONS.

CHICAGO :
GEO. K. HAZLITT & Co., PUBLISHERS.

1896.

Copyrighted by
GEO. K. HAZLITT & Co.,
1896.

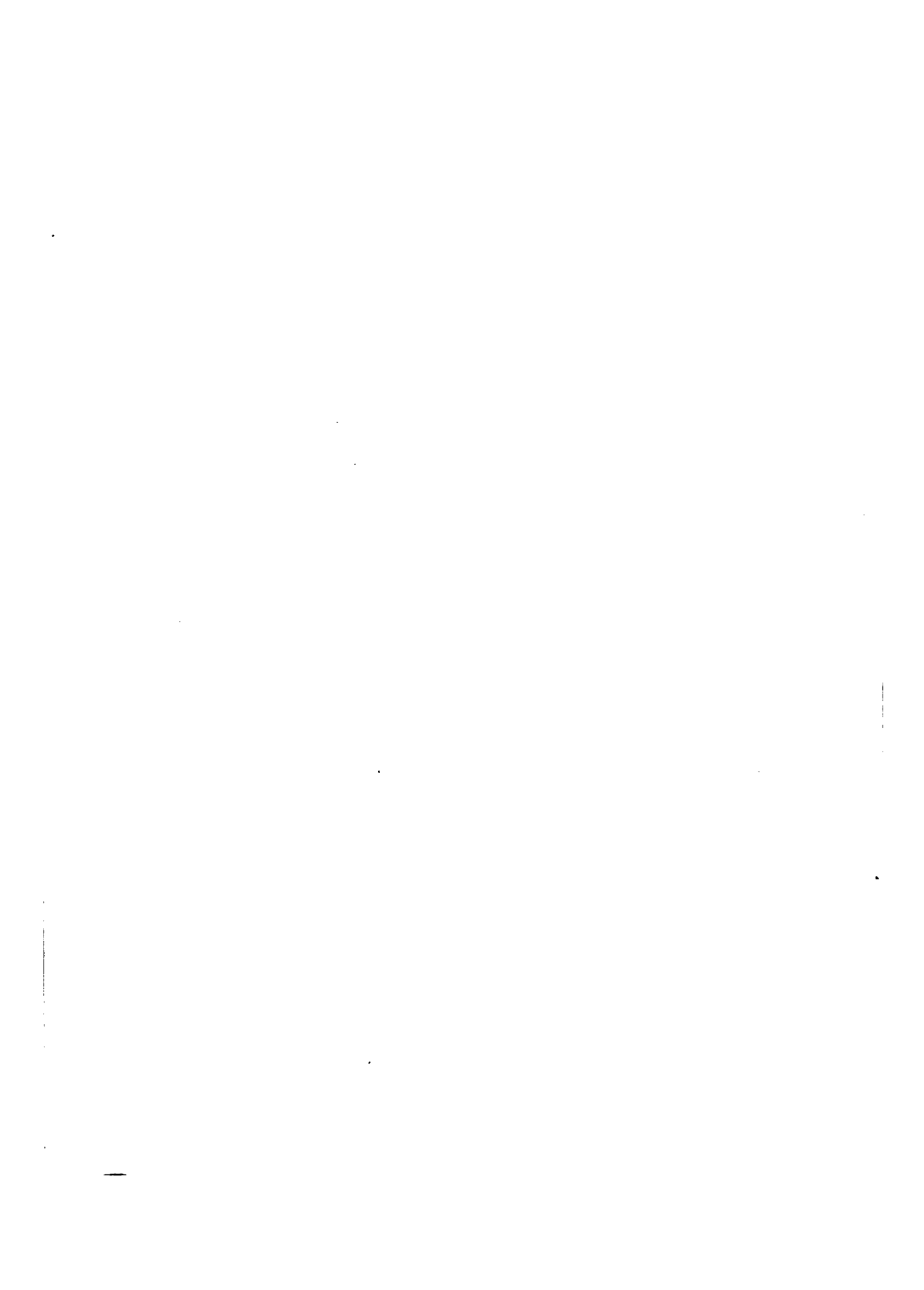
Recd. 4-21-38. ejm

PREFACE.

An apology, to possess its highest value to all parties concerned, ought to be both prompt and unsolicited. The writer of the following pages desires, therefore, to apologize in advance for the short-comings and imperfections which may be found in this brief review of some of the steps of mechanical progress in the manufacture of watches on the American System. The work of preparing this brief history was performed in connection with the every-day factory duties of the writer and, therefore, subject to frequent interruptions and delays. It was not expected that it would be embodied in any more permanent form than in the columns of the monthly trade journal for which it was written.

E. A. MARSH.

Waltham, Mass., February, 1896.



INTRODUCTION.

As mankind develop in intelligence and culture, their wants become more numerous and varied and their requirements more exacting. The supply of one want but briefly anticipates the creation of a new one, which in turn demands satisfaction, so that the great and growing business of the world seems to be to supply its various wants. To a certain extent this supply business possesses the nature of a barter, in that it is an exchange of commodities, not always a direct exchange, indeed, it seldom is so simple a matter as that, yet in an indirect way all business as such is simply a channel through which the multitudinous wants of mankind find their supply. As the great majority of people have certain wants in common, the matter of providing an adequate supply becomes very important, and calls for special means or agencies through which to work, so that it follows that the better the means of supply the cheaper can be the supply obtained and the want satisfied. So that it is by no means an indication of laziness or indolence in an individual if he uses his brains in devising an easier, or

quicker, or cheaper, or better method of performing his work. On the contrary, it will in many or in most cases prove quite the contrary fact.

It is one of the inherent conditions of human nature, especially of physical nature, that it is susceptible to fatigue. It is also a fact that a condition of weariness is not conducive to the attainment of the highest results, either in quantity or quality of work produced. If one of the qualities demanded in any certain kind of work be the highest attainable degree of uniformity, it will be readily admitted that the individual workmen, with the certainty of constantly recurring periods of fatigue, which make imperative corresponding periods of rest, is at a great disadvantage when in competition with an impersonal and tireless machine which is capable of producing work of a like kind. The man gets tired, or nervous, or is not feeling well, or is inattentive, or careless and indifferent. The machine has no such weaknesses, and though its work is not held up to the standard quality by any domination of its own conscience, yet its mechanical functions are so invariably exercised that its product of work will surpass that of its human competitor, not alone in quantity, but in exact uniformity as well. How much better then is a man than a machine? Within certain limits the machine is the

better, for the reasons already stated. Still, the powers or capabilities of the machine are limited to a very narrow compass, i. e., it can perform the particular duty for which it was made, whereas the man, the human machine, is capable of adaptation to the performance of a great variety of duties. But *within the field of its capacity the properly designed and well made machine will outstrip the man*. Especially will this fact be apparent in the production of articles which from their nature demand the exercise of special skill and unremitting care and attention in their fabrication. Work of such nature calls for a great degree of nervous strain on the individual engaged in producing it. The expenditure of nervous energy entails fatigue, which in turn reduces the ability to exercise the needful skill or to concentrate the operator's attention, and a lessened quantity and inferior quality of product results.

If it is desired to produce large numbers of articles which shall be substantially alike, and which are composed of a variety of parts, it is evident that economy in production will be best secured by a subdivision of the labor, by which large numbers of similar parts shall be produced by the same workman. It is also evident that if the large number of required pieces whose function is the same. can be made with dimensions exactly uniform,

there will result a great reduction in cost of manufacture because of the avoidance of any individual or special fitting of the various parts.

Such a system of manufacture has within the last fifty years come into very general adoption in all extensive concerns, and from what has been said, it will be evident that its success must depend upon the adoption of machines, and the comparatively small amount of individual skill demanded. So far as is known to the writer, the most complete and comprehensive system of manufacturing on the interchangeable system, in its earlier years, was introduced by the United States Government for the manufacture of army muskets, at the United States Armory at Springfield, Mass. Credit for a large share of the mechanical excellence of that system, and for the invention of many of the ingenious machines then and still in use for that work, belongs to the then master mechanic at the armory, Cyrus Buckland. One of the interested students and great admirers of that ingenious mechanism in those early days was a young Boston watchmaker named Dennison, who was convinced that by the construction of suitable machines it would be not only possible but entirely practicable to manufacture the delicate mechanism of the pocket watch on the interchangeable system; and feeling that such a scheme was

feasible and might be made to yield a good manufacturing profit, he endeavored to establish a watch factory, to be conducted on that system of manufacturing. After years of delay he succeeded in organizing a company and in beginning the work of preparation. As his plan was to substitute machinery for skilled labor to a large degree, it was of course needful to design and build the special machines required. The field was new; experience could afford little assistance; money was by no means plentiful, and it was therefore needful to proceed with caution, so that expensive mistakes might be avoided. It was, moreover, an uncertain matter as to the magnitude of the business to be done, assuming that the new manufacturing system should prove successful. It is no detraction from the ability or the ingenuity of the original mechanics of the watch factory that they did not at that early date attempt the use of elaborate and complicated machines, such as we now have in use. Such an attempt at that time might indeed have given evidence of inventive or mechanical ability, but it would also have been an indication of poor business judgment, and would have been a waste of the little money then available. Large capital is an absolute necessity in the manufacture and employment of automatic watch machinery to any general extent, and in this branch of

business, as well as in almost all others, the larger concerns possess this great advantage over their smaller competitors.

If it were possible, it would be interesting to review the various forms of machines which have successively been used in watch making on the American system; which system, as has been suggested, consists in making large numbers of pieces of exactly uniform dimensions, so that they may be used interchangeably. As the only practical means of such manufacture, the system proposed and demanded special machines for the performance of the work, not only for the sake of economy, but also to do away with necessity for special skill in the individual workman. Such a review is, however, impossible. Most of the discarded or displaced machines have been destroyed. But of those which remain we may make a brief study, sufficient we trust to note the direction and path of progress in the evolution of the more complicated and costly machines now in use.

EVOLUTION OF AUTOMATIC MACHINERY.

CHAPTER I.

In the review of machinery employed in watch making, it will be both natural and proper to consider, in the first place, the machines employed in the production of the plates. Of course the great bulk of the work on the plates is in the nature of turning, which involves the use of special chucks, and to a certain extent, of special lathes also. By the death of the late Ambrose Webster, the writer is deprived of an authority in certain matters of historical nature, for Mr. Webster was, during some of the early years of the Waltham factory, immediately engaged in the making of tools and machinery, and was well informed as to the origin of some of the foundation devices which have been universally adopted in American watch factories, and which by their evident value have also commended themselves to the attention of manufacturers in other lines. One of those primary devices, and perhaps the most important, is that of the "draw-in chuck," so called from the method of its

operation, it being caused to grasp the enclosed object by being drawn into the tapering mouth of the lathe spindle. It is also known as the "split chuck," from the form of its construction. Probably the oldest form of such chuck is found in the "Aiken's awl," (Fig. 1)



Fig. 1.

which is still in use in the hollow awl handle, filled with an assortment of awls and other simple tools. This awl handle is constructed with a sleeve or socket, the mouth of which is bevelled or tapered, and the inner end tapped with a screw thread. The chuck, at its inner end, is threaded, while its outer end is bevelled to correspond with the socket which receives it. The projecting part is made square, to fit an accompanying wrench, and the chuck being split nearly to the inner end, forms two jaws which grasp the tool as the chuck is screwed in. It is not now known whether in originally adapting this chuck to watchmaking lathes, the projecting squared portion was retained, though it is believed that it was so retained for a time, but was

succeeded by a solid rod or screw which extended through the axis of the lathe spindle and was operated by some sort of wrench applied to its outer end. This form of construction naturally suggested the use of a permanent handle, i. e., the "hand wheel" which is now in universal use. Still later the solid rod was succeeded by a hollow one, and the form of the closing chuck modified, until there was evolved the spring chuck and draw-in spindle, as now used in all watch-maker's lathes. Credit for the latter stage of improvement doubtless belongs to Mr. C. S. Moseley, who introduced it while the original of the Waltham watch factory was located in Roxbury, Mass.

Without doubt the early form of this split (or spring) chuck was used for holding wire, or small pieces of cylindrical form, but later the outer end of the chuck was enlarged, so as to hold the round discs of brass used for plates and wheels. But for holding work to be turned on its face, and which it was desired to duplicate or multiply in large numbers, and of exact and uniform thickness, the "draw-in chuck" possessed an inherent imperfection. If, in operating upon a succession of pieces, which it was desired to have of uniform thickness, one piece should be a little larger than another, the chuck could not be drawn into the taper mouth of

the spindle to the extent which the smaller pieces would allow, consequently the larger pieces would be turned thinner than the smaller ones. A similar effect would be produced by unduly straining the draw-in spindle. To overcome this inherent fault, some one (probably Moseley), very ingeniously modified the construction of the lathe so that the *chuck should be held stationary*, as to any lengthwise motion, and the closing of the chuck be effected by the endwise movement of the outside spindle. This form of construction, although varied in some particulars, has been in almost universal use in all watch factories for about thirty years or more, and will doubtless continue. This form of lathe is known as the "three bearing," or more properly, "the slide spindle lathe." (Fig. 2.)

In 1873, Mr. C. V. Woerd designed and patented a modified form of "slide spindle lathe," which was nominally a *two-bearing lathe*, the third bearing being obtained by making a long telescope fit of the draw-in spindle in the rear end of the running spindle. With very nice fitting, such a lathe would run fairly well for a time, but it never was a satisfactory form of construction, and was abandoned. In the view of this lathe, as shown (Fig. 3), it will be observed that it is made to close the chuck without the use of the "hand-wheel,"

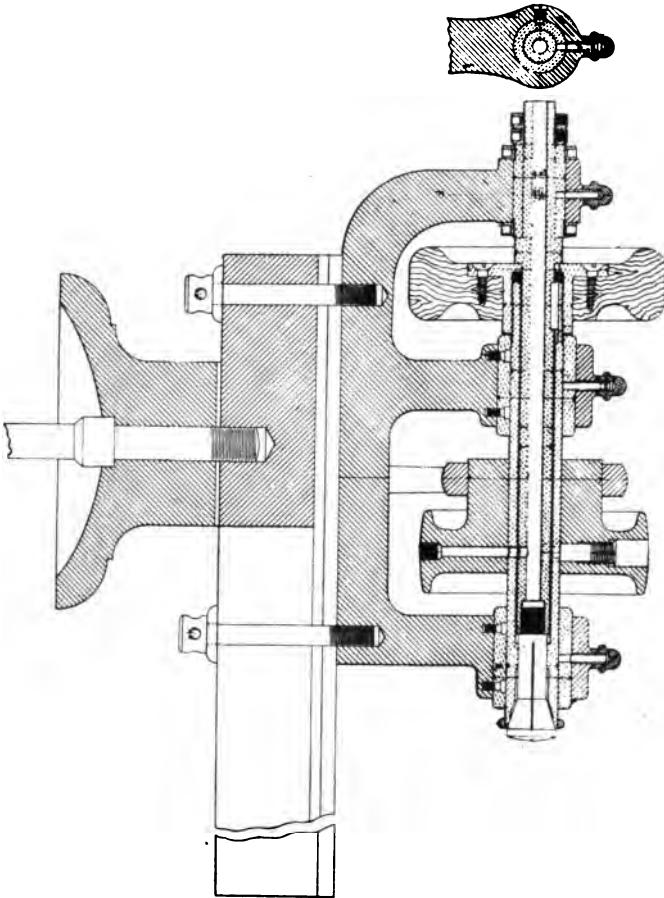


Fig. 2.—Three-Bearing, Slide Spindle Lathe.

the closing being performed by the action of a stiff spiral spring, mounted on the draw-in spindle, while the opening was done by means of a foot lever connected

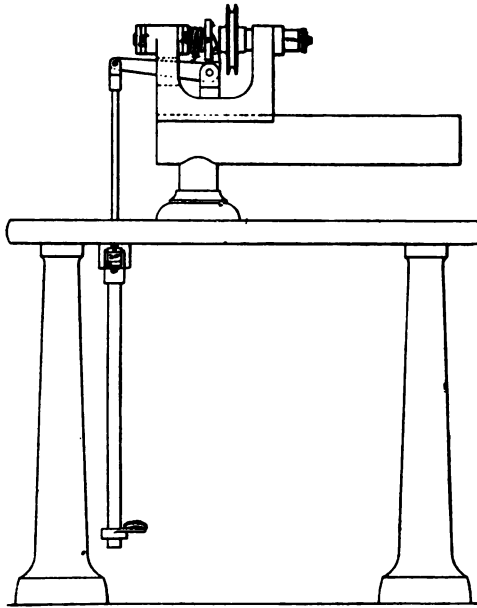


Fig. 3.—Woerd's Two-Bearing Slide Spindle Lathe,

with the forked bell crank lever attached to the lathe head. While this was not the original form of self-closing lathe, (as springs had for many years been used to operate the draw-in spindle of small lathes for very light

work), yet it was an advance toward a better form of self-closing lathe (Fig. 4), which has, by successive steps, reached a form of construction so useful as to be extensively employed, largely for the reason of its adaptability to automatic operation, and, from that fact, being peculiarly fitted to be incorporated in the more

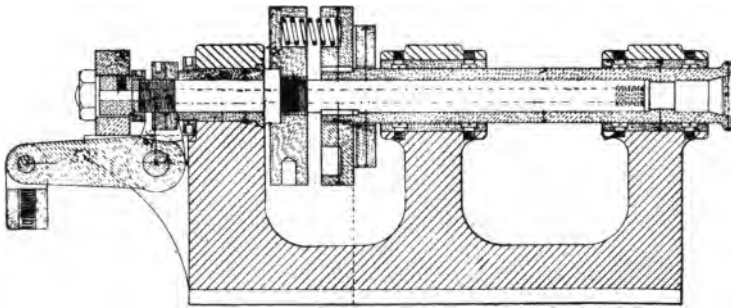


Fig. 4.—Self-Closing, Three-Bearing Slide Spindle Lathe.

complex forms of machinery which are made automatic throughout.

Having thus briefly sketched the growth of the chuck and the lathe, we reach the point of their joint operation in the manufacture of watch plates. It was the early method in this factory to employ the slide spindle lathe, above described, with hand wheel for closing and opening the chuck for holding the plates, in conjunction with the common form of slide rest with the two slides, each

movable by screws turned by the two hands of the operator. Later the hand wheel was succeeded by the self-closing form of lathe, the opening of the chuck being performed by a combination of levers operated by foot. Then came the substitution of levers in place of the feed screws for manipulating the slide rest. Still later came an attachment to the lathe head for operating another tool, which served to round or bevel the edge of the plate after being faced by the slide rest tools.

A story is told of a young musical student who claimed that he could write a musical composition which should be correct, and yet be beyond the ability of his teacher to play. As his teacher expressed doubts as to the young student's ability in that direction, he was requested to submit his composition for trial. On laying it before his teacher for him to play on the piano-forte, there seemed to be nothing unusually difficult, until he came to a passage which demanded the use of the two hands at near the extremities of the keyboard, while there was call for a note to be struck on one of the keys near the center. Of course the professor stopped, with the exclamation that "such a passage could not possibly be played by any one." But the youth assured the master that it was not only possible



Fig. 5.—Plate Turning Lathes, with Double Lever Slide Rest and Cornering Tool.

of execution, but was by no means difficult, and seating himself at the instrument, he began the composition, and when he reached the peculiar passage he bowed his head and struck the required key with his *nose*. In the case of this plate-turning lathe, the operator's two hands are engaged in manipulating the slide rest, and his two feet in stopping and starting the lathe, and opening the chuck. As a means of operating the cornering stool above mentioned, the *knee* of the operator is brought into service with perfect success.

It is obvious that a person could attend to but one lathe of the kind described, and that the watch plate would require a large succession of turnings, each of which would require a special chuck, consequently a very large number of lathes would be demanded, beside the consumption of much time in changing chucks and adjusting the tools.

Within two years, however, Mr. D. H. Church has constructed two machines for plate turning, which mark a new departure in that direction, the novelty being in their adaptation to the performance of a number of turnings, equivalent to a number of machines and operators. The first of these machines is designed for turning the recesses in pillar plates, such as are shown in the accompanying illustration (Fig. 6), which shows the train side

of a 16-size plate, with recesses turned for the barrel, the escape wheel, the pallets, the balance, and the bearing for the intermediate setting wheel, also a small recess for the center pinion. The blank plates, having been faced on both sides, and having the diameter turned, and the dial feet holes made, are placed in a tube at the left hand end of the machine, whence, they are taken, one at a time, by a swinging carrier arm, and are placed in the chuck of the first running spindle. By the action of a cam on a shaft below and parallel with the running spindle, which is at rest, one of the slides of the compound tool carriage is moved *toward* the work, which carries the turning tool into operative position, and the chuck spindle being at the same time set in motion, the tool commences its work of cutting the recess, beginning at its outer edge. When the tool has cut to the proper depth, another cam comes into action, and the tool is moved across the work, turning toward the center of revolution. If a slight boss is desired at the center of



Fig 6.—Sixteen size Pillar Plate, showing six recesses made by Automatic Machine.

the recess, the tool is withdrawn at the proper time and distance, and when the recess is complete the turning tool is automatically drawn back and returned to its original position, which allows room for a second carrier to swing over into position to receive the recessed plate. By this time the revolution of the chuck spindle has ceased, and this second carrier moves up into contact with the plate, and as it recedes again it carries the plate with it, and swinging over, it moves up and deposits it in the chuck of the second spindle, but in such position that the succeeding recess will be made in its proper location on the watch plate. Another and suitable tool is now brought into action in a similar manner to the first, and when its work is completed it retires, and a third carrier takes the plate and places it in another chuck. In the meantime the two preceding chucks have received new plates, and so the work progresses simultaneously, six recesses being made successively in as many plates, each unlike all the others in size, position and form.

The last carrier in the series deposits the recessed plate in a tube at the extreme right hand end of the the machine, By a change in chucks, etc., the turnings on the dial side of the plate can be made in a similar manner. The boldness in the conception of this



Fig. 7.—Automatic Pillar Plate Recessing Machine.

machine, (Fig. 7) will be appreciated when it is realized that the watch plate must be placed in each succeeding chuck in a different position, and that it is required to be placed on three pins which fit in the three dial feet holes.

Another form of plate turning machine is designed for turning recesses in top plates, which are held in self-closing chucks, instead of being placed on pins as is the case with pillar plates. This machine, which is shown in the accompanying view, (Fig. 8) is exceedingly novel in its movements, especially in the action of the transfer carriers, which instead of swinging over, like those on the pillar plate machine, are made to swing around. This form of motion involves the necessity for an additional movement in a vertical direction to clear the tool carriage. In this case, as in the other, the blank plates are taken from a tube, where they have been placed by the attendant, and placed in the chuck, and are also delivered in another tube when completed. Another difference in action consists in the movement of the work toward the tool, instead of the tool toward the work. But the most novel and curious action is that of the transfer carrier. As this arm swings *around*, its ordinary effect would be to reverse the watch plate so that it would be placed in the succeeding chuck with



Fig. 8—Automatic Plate Recessing and Facing Machine.

the opposite face presented to the cutting tool. In some cases that change would be desired, but where it is desired to make the successive recesses on the same side, the carrier reverses the plate during its transfer, so that it is placed in the second chuck with the same



Fig. 9.—Showing Recessing and Facing of Top Plates.

side out, but with the center of revolution at what ever point desired. The accompanying illustration, (Fig. 9) shows the several recesses and the facing of both sides of plates.

CHAPTER II.

It should be understood that this work is not intended to describe the manufacture of watches, for that would require volumes, but to briefly note some of the steps in the evolution of special machines, which characterize the "American system" of watchmaking. It must be understood that only a few of the more prominent machines can be considered, and that only a general description of those can be given.

Having briefly considered the turning of the plates, we will defer, for a time, any mention of other operations on that part of the watch movement, and review the successive forms of the machines for turning the various arbors, staffs and pinions, which constitute some of the moving parts of the watch.

The history of the American Waltham Watch Factory does not extend back to that indefinite period when power was obtained by means of the foot wheel, and the turning tool was simply a graver held in the hand of the operator; but only to the time of the lathe and slide-rest, whose feed-screw was operated by hand. For a time, the turning of all staffs and arbors was performed in this

way. But this method was succeeded by a form of semi automatic turning lathe, the exact form of which the writer is unable to learn. Succeeding this, came an improved form of lathe, in which the tool was caused to move with a uniform speed and to a desired distance



Fig. 10.—Moseley-Webster Staff Turning Lathe.

and then automatically withdrawn from contact with the work and returned to the point of starting. The accompanying illustration, (Fig. 10), shows one of the oldest form of lathes used in this factory, which can be found (and unfortunately minus one of its spindles). It will be observed that at the left hand end of the

machine there is a combination of levers, designed to provide for turnings of various lengths without necessitating a change of feed cams. It is the understanding of the writer that the combination levers were designed by Mr. Ambrose Webster, while the invention of the lathe should be credited to Mr. Chas. S. Moseley.

The next illustration (Fig. 11), shows a later form of automatic staff turning lathe, which embodies substanti-



Fig. 11.—Staff Turning Lathe (Vander Woerd Pattern.)

ally the same principle of mechanism as the earlier machine, but differently arranged, and of much heavier construction. The cam shaft, at the back of the machine, is driven by a worm and worm-gear, not

shown. At the extreme left hand end of this shaft is shown the feed cam, the acting face of which gives motion to a rack lever, which indirectly communicates motion (endwise) to the tool carrying spindle, one end of which is seen projecting through the end of the machine. The opposite end of this spindle enters the projecting cylinder at the right hand side of the machine, which cylinder contains a spiral spring, which serves to carry the spindle in the reverse direction to that imparted by the feed cam. About midway of the length of this spindle is attached the tool holder, which is compound in its construction, to allow for the desired elevation of the turning tool, and also to provide a means of moving the tool at a right angle to the axis of the staff or arbor to be turned, this latter motion serving to withdraw the tool from contact with the work, or, when so desired, to enable the tool to perform a "squaring out" or "facing" cut. To effect this motion an arm of the tool carriage extends back underneath the cam shaft and is acted upon by a suitable cam, which depresses the arm, and thereby slightly turns the feed or tool carrying spindle, thus moving the tool away from the work, and, while thus held back, the action of the feed cam allows the tool to return to its starting point, in readiness to act upon the next piece of work. Devices

for so governing the action of the tool as to turn tapering staffs are also provided, but cannot be seen in a general view. In staff turning it is sometimes desired to have one of the spindles in which the work runs fixed and the opposite one movable, to allow of the reception and removal of the work, and at other times it is needful to make the opposite spindle the fixed one. Ready provision is made for these requirements by means of suitable binders, or clamps provided with milled nuts, shown on the front of the spindle heads. When one of these nuts is screwed down so as to clamp the spindle firmly in place, the opposite one is turned back so as to leave the spindle on that side free to slide. When the staff to be turned is inserted in position, the free spindle is moved up into proper contact with it, and as the lathe is put in motion, a suitable cam on the rear shaft acts through an adjustable lever, and binds the slide spindle in place until the turning tool has completed its work and has returned to its starting point, when the spindle is released and can be slid back, and the completed arbor removed.

This brief, and perhaps not very clear explanation of the action of this staff turning lathe, is given for the benefit only of those readers who have had no opportunity of visiting a watch factory. As has already been said, this is substantially the form of staff turning lathe

in use in American watch factories, and probably to some extent may have found its way into some European factory also.

Some years ago the writer designed another form of staff lathe, which, while in many respects similar to the

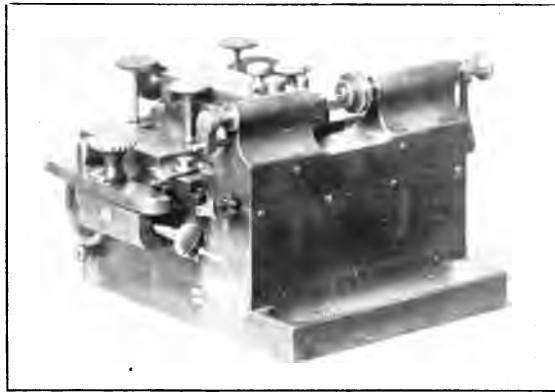


Fig. 12.—Marsh Staff Turning Lathe.

foregoing, yet possessed several features of novelty and special advantage. The accompanying illustration, (Fig. 12), will serve to give a general idea of its appearance. It was much more heavy and solid, and consequently assured a greater accuracy. It also had superior devices for taper turning in either direction, and in connection with such turning, it provided for facing either, hollow,

crowning, or at a right angle to the axis. It was also arranged to turn special pieces in which a part of the turning was to be straight and when a certain point was reached the turning continued at any desired angle.

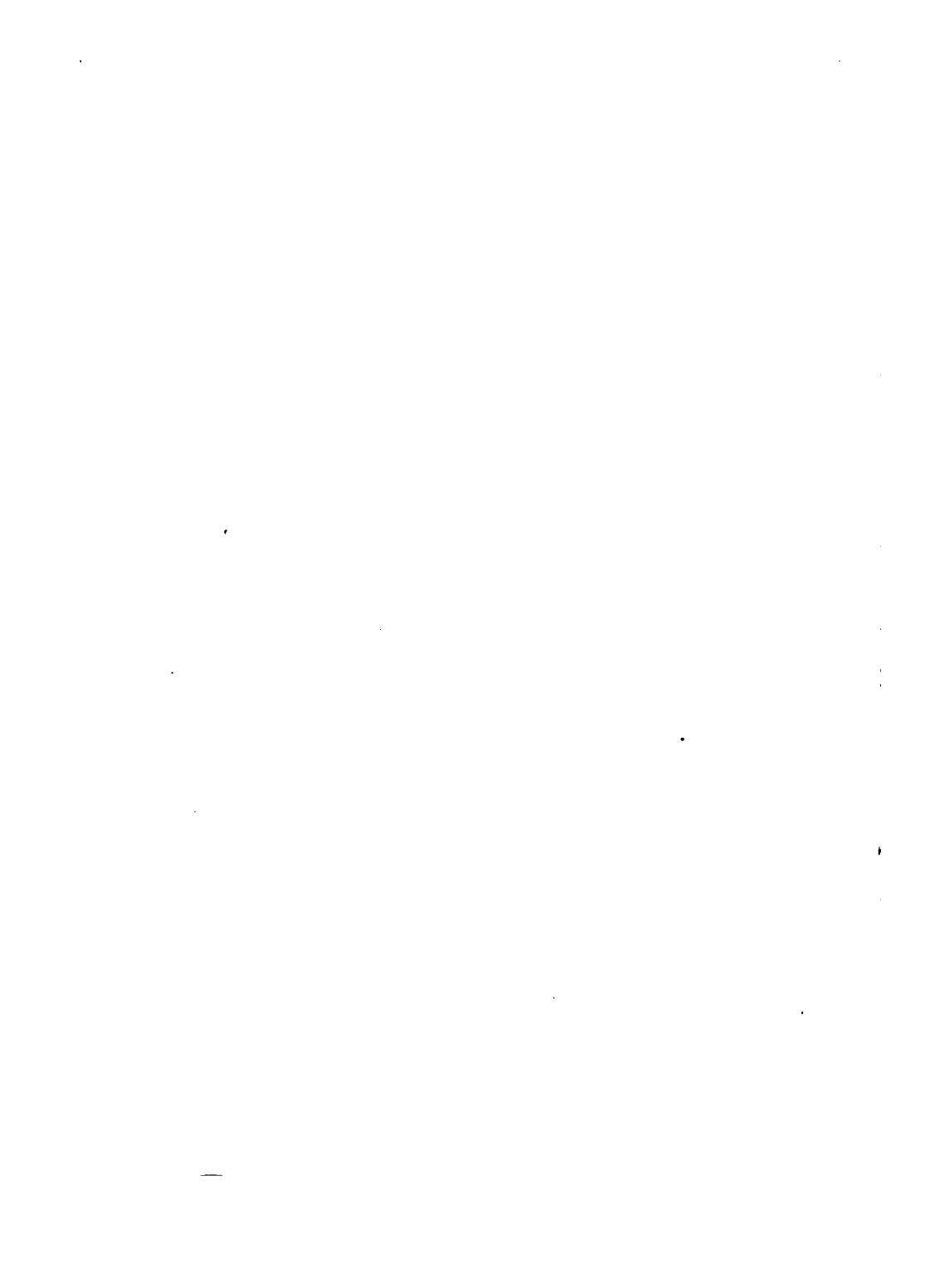
Machines of all the above forms are to a large degree becoming obsolete in the American Waltham Watch factory, they having been largely displaced by the radical improvements designed by Mr. D. H. Church. It should be said in connection with all the forms of staff turning lathes above described, that they are but semi-automatic. Each piece to be turned, required to be "dogged" as a means of driving; the dog engaging with a suitable finger, or horn, on the driving whirl. The applying and removing of the "dogs" giving constant and lively employment to the attendant, and making impossible the running of more than a single lathe by one operator.

In the earlier days of American watchmaking the pinions were to a great extent made from "drawn pinion wire," but in later years the use of such special wire was discontinued, and the use of plain round steel wire was adopted. For years it was customary to cut the plain wire into short pieces, making suitable allowance in length for finish. The common way was to "chop off" the wire by means of an ordinary wire cutter or by a

special chopping machine. These short pieces were then placed one by one in a spring chuck in a lathe, and one end carefully pointed. After the entire lot had been pointed on one end, they were placed in another chuck, provided with a suitable interior stop, against which the pointed ends of the blank should bear, in order to insure exactness in the length of the blanks. Subsequent "rough turning" of these blanks, which were still held in spring chucks, removed a large portion of the surplus metal, bringing them into a suitable condition to be turned in the automatic staff lathes. When acted upon in the staff lathes the blanks were held and revolved on "dead centers," each piece as has been said, requiring to be dogged by the operator.

Some of the smaller staff blanks, like pallet arbors, were cut off in a lathe and one end pointed at the same time, but all blanks, whether large or small, required to be dogged at each individual turning. And, owing to the minuteness, and consequent weakness of most of the pieces, only a small amount of metal could be removed at any single turning, consequently the required turnings on some staffs were quite numerous, and in pieces such as the balance staff, which contains numerous sizes and shoulders, the number of individual turnings would be ten or twelve, and in order to avoid injurious springing

of the staffs it was needful to alternate the turnings, so that the reduction in size should be gradual and uniform on both ends.



CHAPTER III.

In the preliminary, or rough turnings of the various staffs, a radical improvement was initiated by Mr. C. V. Woerd, about fifteen years ago, consisting of an automatic roughing out machine, which was so designed as to receive a rod of steel wire about twenty inches long, which was held by the ordinary self-closing chuck, whose evolution has been described. In suitable relation to the mouth or face of this chuck, was a turning and pointing tool, mounted on a movable carriage or frame which was actuated by a suitable cam, so that as the wire rod, which projected the proper distance out of the chuck, revolved, this tool was gradually moved forward into contact with it, and cut away a portion of the metal and carefully pointed the end. When this operation was completed the cutting tool quickly retired, the revolution of the running spindle was arrested, the chuck loosened its grasp on the rod, which was then automatically fed forward a proper distance, and again grasped by the chuck, the spindle again started, and a second cutting tool moved forward, which immediately commenced its work of cutting off the steel rod; the severed piece to be

of proper length to form a desired pinion or arbor. But just before the completion of the severing operation, a tubular carrier was moved over into axial line with the revolving rod and then moved back so as to enclose the severed piece, which, when entirely detached from the rod, was left in the carrier, which immediately moved forward and out of the way. The running spindle was again stopped and the chuck released its hold, and the rod was fed forward again, and the first tool was again brought into action, and so this part of the work proceeded. In the meantime, the above mentioned carrier was moved over into axial coincidence with the second spindle whose chuck was in readiness to receive the severed blank contained in the carrier. Immediately the carrier reached its position in front of this second chuck, a push rod moved forward and entered the rear end of the carrier tube and forced the enclosed blank into the mouth of the second chuck, which at once closed upon it. The carrier then retreated a short distance, the push rod was withdrawn and the carrier moved to an intermediate position to await its proper time to secure a second blank from the first chuck. As soon as the carrier was out of the way, the second spindle was revolved, and a cutting and pointing tool began its work of forming the second end of the blank, and when its

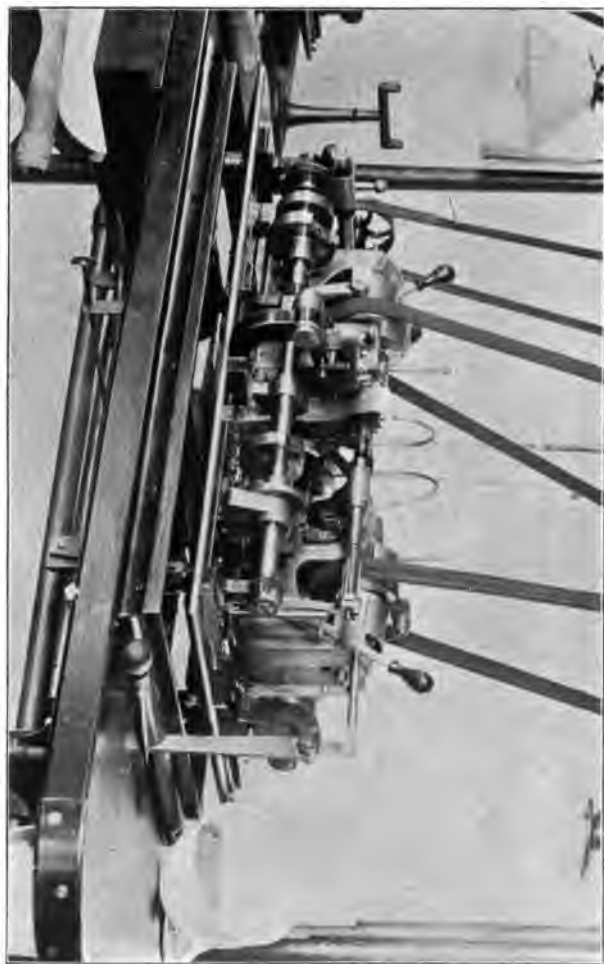


Fig. 13.—Voerd-Marsh Automatic Ronghing Machine.

work was completed the spindle was stopped, the chuck opened and the completed blank ejected and fell into a chute, which deposited it in a receptacle entirely separate from the cuttings, so that the work of separating blanks from chips was entirely avoided. This machine was so arranged that when the wire rod had been entirely converted into blanks, the machine would stop itself, and, unlike some human machines, it would not go through the motions unless it was actually doing work. Inasmuch as these machines were so completely automatic in action, and the wire rods were of a length capable of being cut into a large number of pieces, a single attendant could care for the running of six or eight machines. The establishment of these automatic roughing machines (Fig. 13) served to greatly reduce the cost of staff turning, but there still remained the numerous "finish turnings" to complete the pinions or staffs; and, as has been said, each individual turning required the application of a driving dog. To supplement the work of this machine a radical improvement has been made by Mr. D. H. Church, who has invented and patented an automatic turning machine, which is really a complete battery of staff turning lathes which are located on a single bed or table, and all of whose operative mechanism is driven by a single belt.

A detailed description of any of these complicated machines would be somewhat difficult, and would be uninteresting to the general reader, and will not be attempted. It may be briefly said that at one end of a long bed or table is located a suitable frame, provided with a vertical shaft which at its upper end, carries a disk or plate. On the face of this plate, and near its edge, are turned suitable concentric grooves which are crossed by radial V shaped grooves of proper size and equally spaced. In these grooves are uniformly placed the roughed out blanks, from which are to be formed arbors or staffs. Adjoining this blank holding device is located an automatic staff turning machine, and at uniform distances beyond it are similar machines, sufficient in number to perform all the required turnings on any given staff. Alternating with these machines are upright stands or columns, through whose centers project spindles or shafts. From near the top of these upright shafts extend arms, from which, at their outer ends depend suitable clips or fingers. These shafts have reciprocating motions in both rotary and vertical directions. The foundation device, that which makes this machine entirely automatic, is the one for grasping the blanks while being turned, so that the applying of a separate "dog" is rendered unnecessary. A very

important gain is also obtained by this method of driving, viz.: the ability to remove a much larger amount of metal at a single turning than could be done with the ordinary method of dogging, so that a single attendant is able to produce as many finished pieces as would six, or more, people under the old system. We have mentioned, above, that this machine was arranged to do the finish turnings on staffs or arbors which had been roughed out on another machine, but by the substitution of a cutting off head for the above mentioned blank holding plate, a class of work which requires the removal of a smaller amount of metal can be turned direct from the wire rod, which may be of considerable length, say five feet. The accompanying illustration shows the machine arranged in the latter form. (Fig. 14.)

In operation, a long piece of suitable steel wire is placed in the tube, extending to the left of the machine, with the inner end of the wire projecting slightly from its holding chuck. The machine is then started, and a suitable cutting tool advances and carefully turns the projecting wire to a suitable point. Then by suitable mechanism the revolution of the spindle is stopped, the tailstock spindle is moved toward the chuck to a definite point, the chuck is opened and the pointed wire fed forward till it comes in contact with a suitable center in the

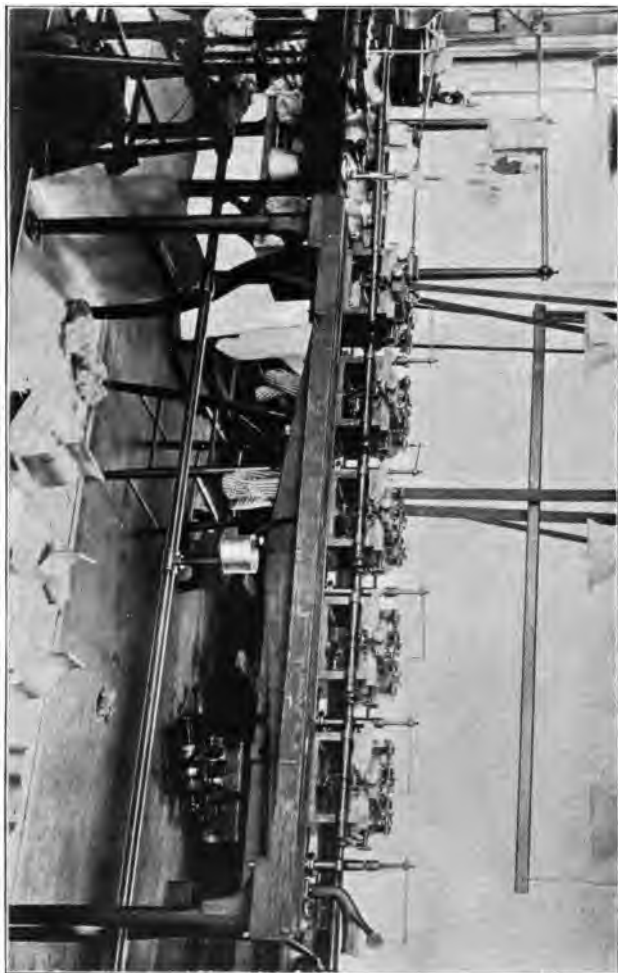


Fig. 14.—Mr. Church's Battery of Automatic Staff Lathes.

tailstock spindle, the chuck is then closed, the tailstock spindle is clamped firmly in place, the spindle is revolved, and the cutting tool moves forward and begins its work of severing the wire. Just before the piece is completely severed, the arm of the upright shaft swings around so as to bring the clip directly over the piece. It then moves down, and the fingers grasp the then severed blank, the tailstock spindle recedes so as to clear the blank, which is then lifted clear of all obstructions and carried around exactly 180 degrees, and then again lowered to a position exactly between the centers of the next machine, which centers then advance and close upon the blank. The fingers are then lifted out of the way, a driving clamp closes upon the blank, the spindle is started, and a suitable cutting tool moves up and commences its work of turning. When this turning operation is completed the tool is withdrawn, the spindle is stopped, the driving clamp is loosened, and the partly turned blank left clear of all obstruction, when a second arm is swung over and another set of fingers descend and grasp the blank, and, lifting it, gets it out of the way just in season to allow a second blank to be inserted, which is then treated in the same manner as the first one. It will be understood that in carrying the blank from one machine to another, the blank is reversed as to its

relation to the head and tail stocks and the cutting tools, the second carrier placing the blank in the third machine so that its opposite end is to be acted upon by the cutting tool. When the work in the third machine is completed, the blank is in the same manner passed along to the fourth machine, and then the fifth, which completes the turnings, and the next carrier drops the completed blank in a proper receptacle. It must be understood that the completion of the turnings in four machines is made possible by the fact that the machines are so arranged that more than one turning is performed in a single machine. It will also be understood that all the machines are in operation simultaneously, each on its own blank, so that after the first blank has reached the receptacle the procession is constant until the rod of wire is completely gone; so that a completed blank is dropped into the dish at the last machine as often as another one is severed from the wire rod at the first one—time about fifteen seconds.

We have already explained that the operation of this machine is made possible by the invention of the automatic dogging or driving device. This device was, however, first applied to ordinary or isolated staff turning lathes, which were modified to adapt them to this improvement. In the first form of such adapted lathes,

the blanks were placed in a suitable hopper, from which they were taken, one at a time, automatically. This form of machine is in quite extended use also.

In all the foregoing forms of turning lathes, the application of some form of dog or driving device is an indispensable feature; but within a year Mr. Church has per-

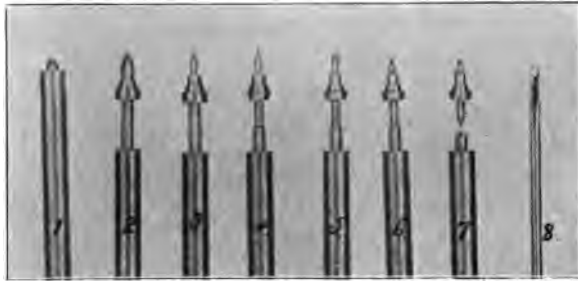


Fig. 15.—Progressive Steps in Making a Balance Staff.

fecting a new form of machine in which that feature is rendered needless, and in demonstrating that fact he adopted the most difficult, delicate and complicated staff in the whole watch movement, viz., the balance staff. These are now made complete, every turning on the entire staff, including both pivots, being done at the rate per machine of 400 per day, or one staff each 90 seconds. We believe that nothing in the way of turning has heretofore been done which could at all compare

with the work of these machines in delicacy, complexity and accuracy. (Fig. 15.)

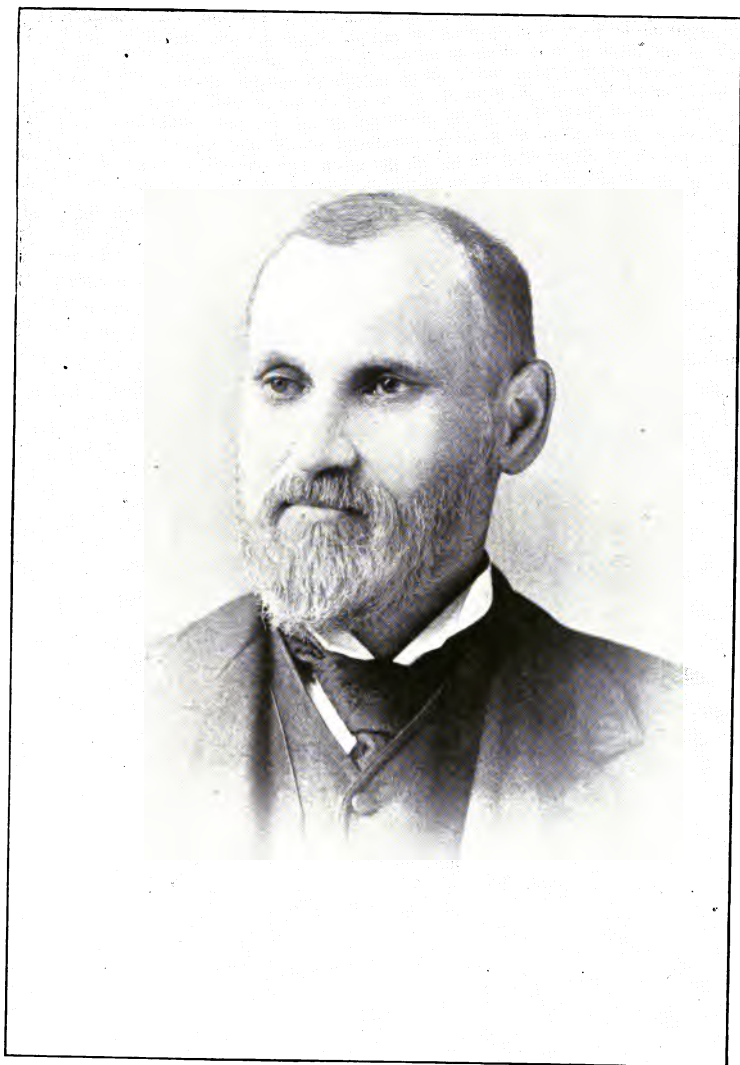
The illustration will serve to indicate some of the progressive steps in the production of this complicated staff, and will also furnish an excellent specimen of microphotography, credit for which belongs to Mr. H. E. Duncan, who is known to many watchmakers.

To better indicate the extreme delicacy of this work, a No. 9 or No. 10 sewing needle is photographed in the same group, and serves to show the relative size of the two articles. Unlike the previously described machine, this machine operates only upon a single blank at a time, completing one blank before beginning upon another, whereas the former carried on all the successive turnings simultaneously, there being as many blanks in progress as there are separate heads to the machine. (Fig. 16.)

The accompanying illustration shows the appearance of two of these balance staff-making machines, but the large number and complication of the different movements required, render it difficult of description; we will therefore make no attempt in that direction.



Fig. 16. Balance Staff-Making Machine.



CHARLES S. MOSELEY.



CHAPTER IV.

To a person who is familiar with the machines now in common use for the cutting of the teeth of wheels and pinions, the means for the performance of such work which were in early use would seem exceedingly crude and unsatisfactory. Possibly they may have been so regarded at that time, but it must be born in mind that the crude appliances which were first used did serve to produce material sufficient in quantity, and of enough excellence in quality to demonstrate that American watchmaking was possible. Improvement in quality and facility in manufacturing were but matters of time and money.

Mention has been made of the fact that pinions were made from specially drawn wire, in which the number and approximate form of the teeth, or "leaves" was given by the drawing dies. This wire was imported, and was received at the factory in pieces about twelve inches long. These were cut into lengths desired for the various pinions, the ends pointed, and the staffs turned. Then came the cutting of the leaves. The form of machine first employed for this work is

unknown to the writer, but he recalls the fact that one of the first jobs of work which he did at the Waltham factory was to make drawings for the remodelling of two of these pinion cutters. But as

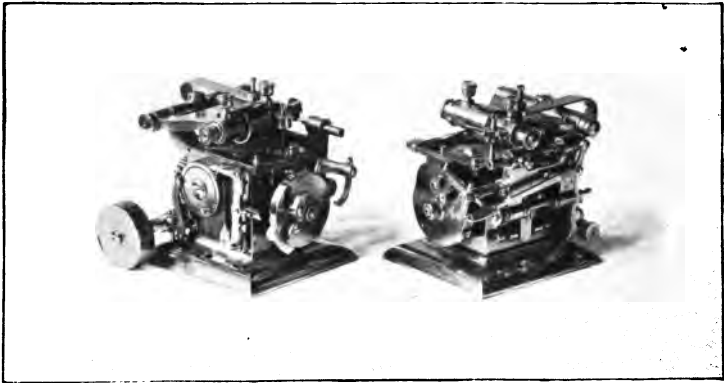


Fig. 17.—Old Style Pinion Cutters.

the work had already been commenced, he is ignorant of the original form of the machines. We have, however, preserved these machines in their improved forms, which are shown in the two accompanying views, and are so placed as to show the mechanism which was largely automatic in action (Fig. 17.)

It will be observed that this machine has no index for the spacing of the leaves, so that it is a matter of

surprise that a safe degree of accuracy could have been attained, but we believe there was seldom any serious trouble from that source. Aside from the fact of these machines being very ingenuous (as will be evident from examination of the illustrations), they afford very good examples of the relative size of machines of those earlier dates, as compared with machines now constructed. These machines occupy a space of considerably less than six inches each way, while machines for similar use as now made, would occupy at least four times as much space, and be proportionately heavy. Just here it may be proper to say that examination of a variety of the earlier forms of the American watch machinery makes it very evident that the idea then obtained that delicate machines were necessary for the manufacture of the delicate mechanism of the watch. This idea was, after the experience of a few years, found to be a greatly mistaken one. But the writer recalls that very early in his connection with the Waltham factory, as he had made a drawing of some new machine, Mr. Ambrose Webster, then master mechanic, said to him, "You are running us to cast iron." But certainly there has been since that time no tendency to return to the practice of building light machinery. At the time of which we are writing the Waltham factory was run under two almost distinct

departments, the "Full Plate Department," under the general charge of Mr. A. T. Bacon, with Mr. A. Webster, at the head of the mechanical department; while the three-quarter plate movements were under the supervision of Mr. Chas. W. Fogg, with Mr. Chas. Vander Woerd in charge of the mechanical work. This arrangement resulted in the establishment of a branch machine shop in connection with the three-quarter plate department, and gave Mr. Woerd the opportunity to exercise his inventive ability in designing and building some special machines, of which mention will be made at appropriate times. One of his earlier machines was an automatic pinion cutter, which was quite ingenious, and also somewhat complicated in action. It used to be remarked that one who was not familiar with this machine could get it into a "snarl" quicker than any machine known. But, when understood, those machines were capable of doing good work and in good quantities. These machines were provided with three cutter spindles, mounted in a revolving head, which were successively brought into action, so as to form the pinion leaves from plain round wire instead of the English pinion wire. We are unable to present an illustration of those machines, for the reason they have all been somewhat remodelled within a few years so as to make

them entirely automatic in action. We will therefore defer further mention of them at this point, but will speak of them hereafter. Shortly after the introduction of the three-spindle machine above mentioned, Mr.

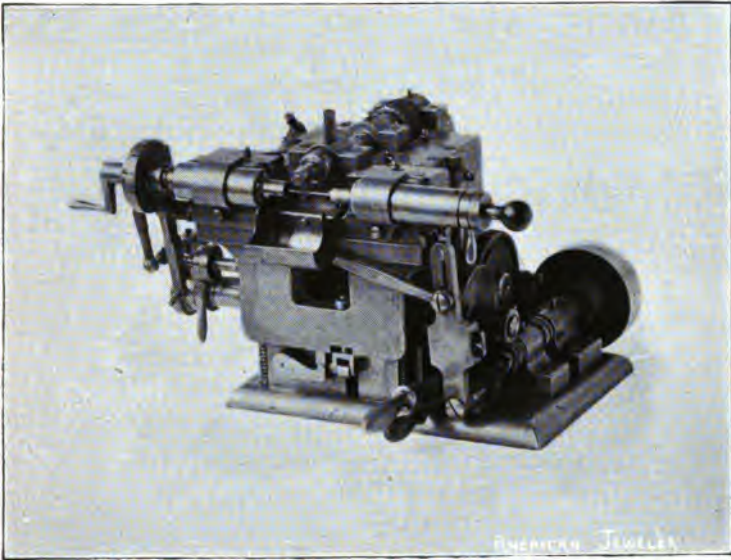


Fig. 18.—Improved Pinion Cutter.

Webster suggested the plan of making a pinion cutter in which the three cutters, instead of being on separate spindles, should be mounted on a single running spindle which should have an endwise movement so as to bring

the several cutters successively into operative position. Such machines were made, and subsequent alterations and improvements brought them into the form shown in the next view (Fig. 18.)

These have proved to be very serviceable machines, and especially adapted to cutting a certain class of pinions which are more difficult to cut than others. In the original Woerd machine there was no provision for adjusting the individual cutters to depth, other than could be made by variation in the relative diameters of the cutters themselves, which rendered the desired accuracy an attainment of a good deal of difficulty. But the single spindle machine was provided with means for *adjusting each cutter* in two positions, so that although the cutters are fixed in their relation to each other on the running spindle, yet in operation they are entirely independent. The single spindle machine has proven to be most excellent in plan, and has been adopted in subsequent forms of pinion cutters, and has to a certain extent been copied by builders of machinery for use in other factories.

It is generally a fact that an individual who is to any considerable extent, engaged in the production of articles of any given nature, will naturally have some favorite form of construction. Particularly is this true

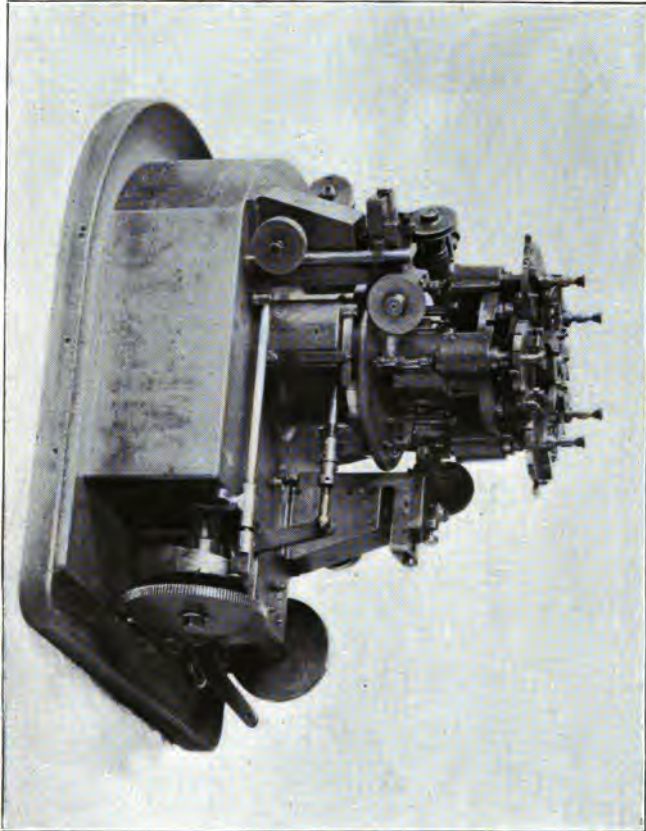


Fig. 10.—Revolving Cannon Pinion Cutter.

in the designing of machinery. It has for many years been a theory of the writer that in the production of large numbers of pieces, or articles of uniform dimensions, the economical method of manufacturing is to "maintain a procession," and a procession to be endless must of necessity proceed in a circle. Circular machines have therefore been a favorite form. The most serious objection to such a form of construction lies in the essential fact, that a great degree of accuracy of workmanship is required. But if such accuracy can be secured there can be no question of superior efficiency.

The next illustration (Fig. 19) shows a machine of this nature which was used for several years in cutting cannon pinions. In this machine there was a plurality of spindles for the holding of the pinions. Each of these spindles was provided with an index, and, as they were arranged around a common center, the entire number were operated simultaneously. After the indices had completed a revolution, the spindle-carrying-head was caused to automatically make a partial revolution, which brought each spindle into operative relation to another tooth-forming-cutter. These cutters, to the number of three or more, were mounted on double slides, and were moved in unison, the cutters

performing their work, then being withdrawn and returned to their former position, and then moved forward, and, the index having in the mean time moved one space, the cutter advanced and cut a second tooth. After all the teeth in the pinion had been cut, or blocked out, by the first cutter, it was presented to the action of the second cutter, as has been said, and then to the third, and, if desired, to a fourth also. As this machine had one more work spindle than it had cutters, there was always a vacant spindle into which the operator could insert a new blank. And as fast as *one cutter* could perform its work on the pinion presented to it, just so fast would a pinion be completed and removed, and its place be filled with a fresh blank. The objectionable feature in this form of machine has already been stated, viz.: the difficulty of obtaining sufficient accuracy in construction to secure the absolute "tracking" of the several cutters. To overcome this difficulty, and at the same time produce a machine of great productive capacity, the machine shown in the next view was made. (Fig. 20). In this machine another advanced step was taken, by the incorporation of the self-feeding feature. This machine is practically the combining of eight machines in one, and is capable of cutting pinions having 7 to 12 leaves; indeed, several kinds may be

cut at the same time. A brief description will serve to explain the operation of the machine, which as is shown in (Fig. 20) is circular in form, and consists of a central column supporting a circular bed, on which is placed a corresponding carriage, on the upper surface of which are eight radial dovetailed grooves in which move a like number of slides each of which carries a complete head and tail stock, the tail stocks being located on the inner end of the slides. At one side of each of these slides is mounted a frame carrying a running cutter spindle. These frames are capable of a sidewise motion, so as to bring successively into operative relation to the pinion blank each of the three cutters on the cutter spindle. Suitable stops are provided for the accurate adjustment of each of these cutters; both as to depth and position of cut. Directly over each of the slides which carry the head and tail stocks, is located a suitable magazine, or pinion blank holder, open at the bottom, where are arranged suitable elastic fingers designed to grasp a single pinion blank.

An upright shaft, located in the center of the machine, gives motion to the entire mechanism. The operation of the machine may be described briefly, as follows: The various cutters being properly adjusted, and the magazines loaded with blanks, the shaft is started, and,

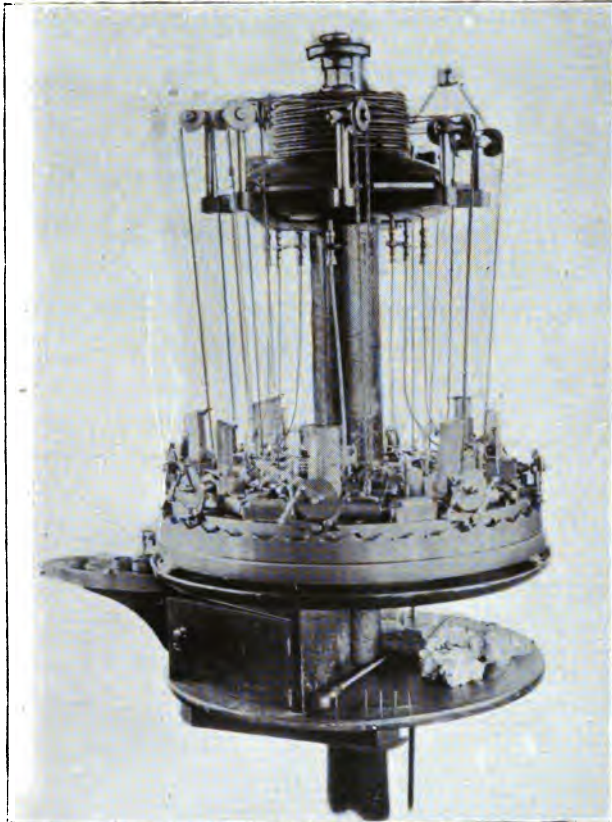


Fig. 20.—Marsh's Continuous Self-Feeding Pinion Cutter.

through the several belts running from the multi-grooved pulley at the top of the machine to the several cutter-spindles, they are put in motion. The circular table begins to travel, carrying all the radial slides above mentioned. When a certain point in its orbit is reached, one of the magazines descends until the axis of the pinion blank, which is grasped in the fingers at its lower end, comes in exact line with the centers of the head and tail stock of that slide. Both the head and tail stock spindles advance toward each other until they close upon the waiting blank, the taper staff of which is forced into a suitable socket in the head stock spindle. The magazine now rises, and as it loses its hold of the pinion blank, it receives into its grasp a second blank which it continues to hold until it shall arrive at the place of deposit, as before.

Immediately the magazine has taken itself out of the way, the slide begins to move in a radial direction in relation to the revolving, thus carrying the pinion blank back and forth over the revolving cutter. As the slide reaches its limit of outward motion, the index on the head spindle is revolved one division, and during the return motion a second tooth is cut. When all the teeth in the blank have been blocked out by the first cutter, the frame which carries the cutter spindle is

moved sideways, so as to bring a second cutter into acting position, which proceeds with its work, and then gives place to a third and final cutter, which completes its work just a little before the revolving table has reached its starting point. The tail stock spindle is now withdrawn, and a little lever on the side of the stationary bed of the machine springs forward just as the outer end of the head spindle is passing it, and quickly drives the completed pinion from the socket, which is then ready to receive a second one. The magazine now descends and the second blank is taken, as before.

It will be understood that while we have been following this first blank in its travel and progress, each of the seven other slides has received its blank, and those are also in all stages of progress, from the first cut of the first tooth to the finishing cut of the last tooth. The procession is uniform and continuous, and when each of the eight radial slides, in its continuous travel, reaches a certain point in its orbit, it delivers a completed pinion, and immediately receives another blank and continues on its way. Unlike the previously mentioned machines, these blanks do not pass from one part of the machine to another to be acted upon by local cutters, but the group of three cutters accompanies the blank on its

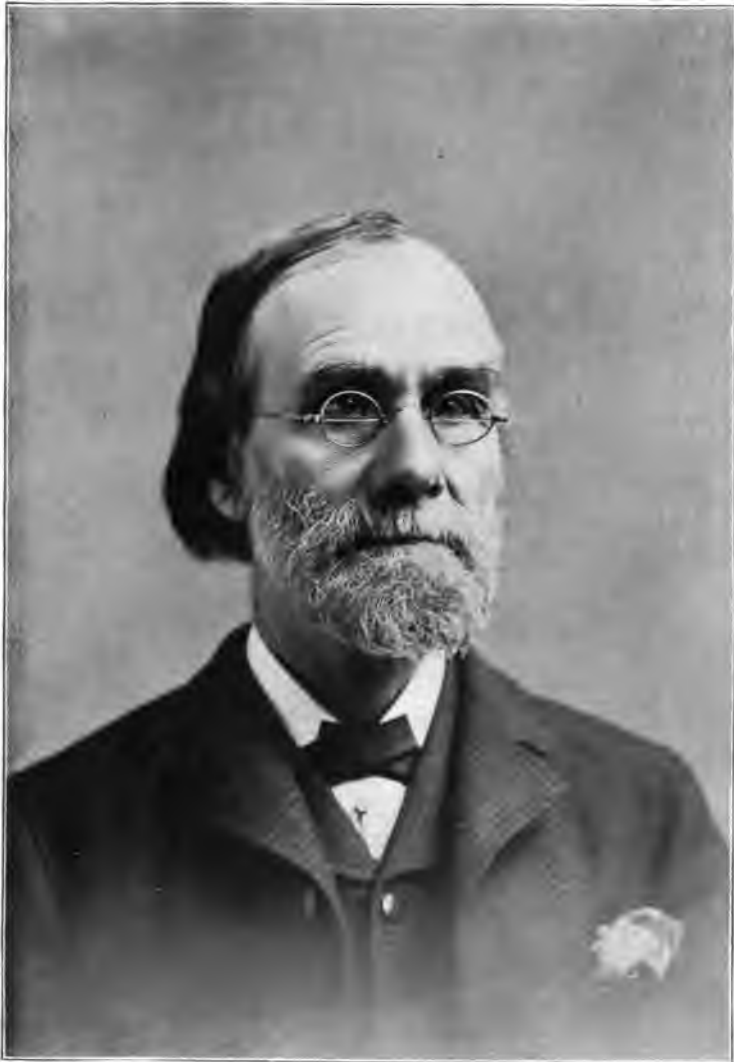
travel. This arrangement permits the cutting of different kinds of pinions to be performed simultaneously. In this machine the work of the operator is reduced to the occasional examination of the completed pinions, and the supplying of the magazines with blanks. Simple devices are provided for rendering each of the slides inoperative whenever so desired, without in any way affecting the action of the others.

The success of the automatic feeding of the blanks and discharging of the finished pinions led to the adoption of equivalent devices on machines formerly in use. The next illustration (Fig. 21) shows a long row of *remodelled machines* of the Woerd type previously mentioned. As these machines are in a row, the attendant, who is able to care for six or seven machines, is obliged to pass from one to another. To permit such movement and, at the same time, to avoid the fatigue incident to long hours of standing, a track is laid on the floor in front of the machines, and chairs are provided with grooved rolls which follow the track, allowing the attendant to glide easily and quickly the entire length of the group of machines under her care. In contrast to this method the previously mentioned machines regularly *presented themselves* to the attendant whose seat was stationary. Since the inauguration of

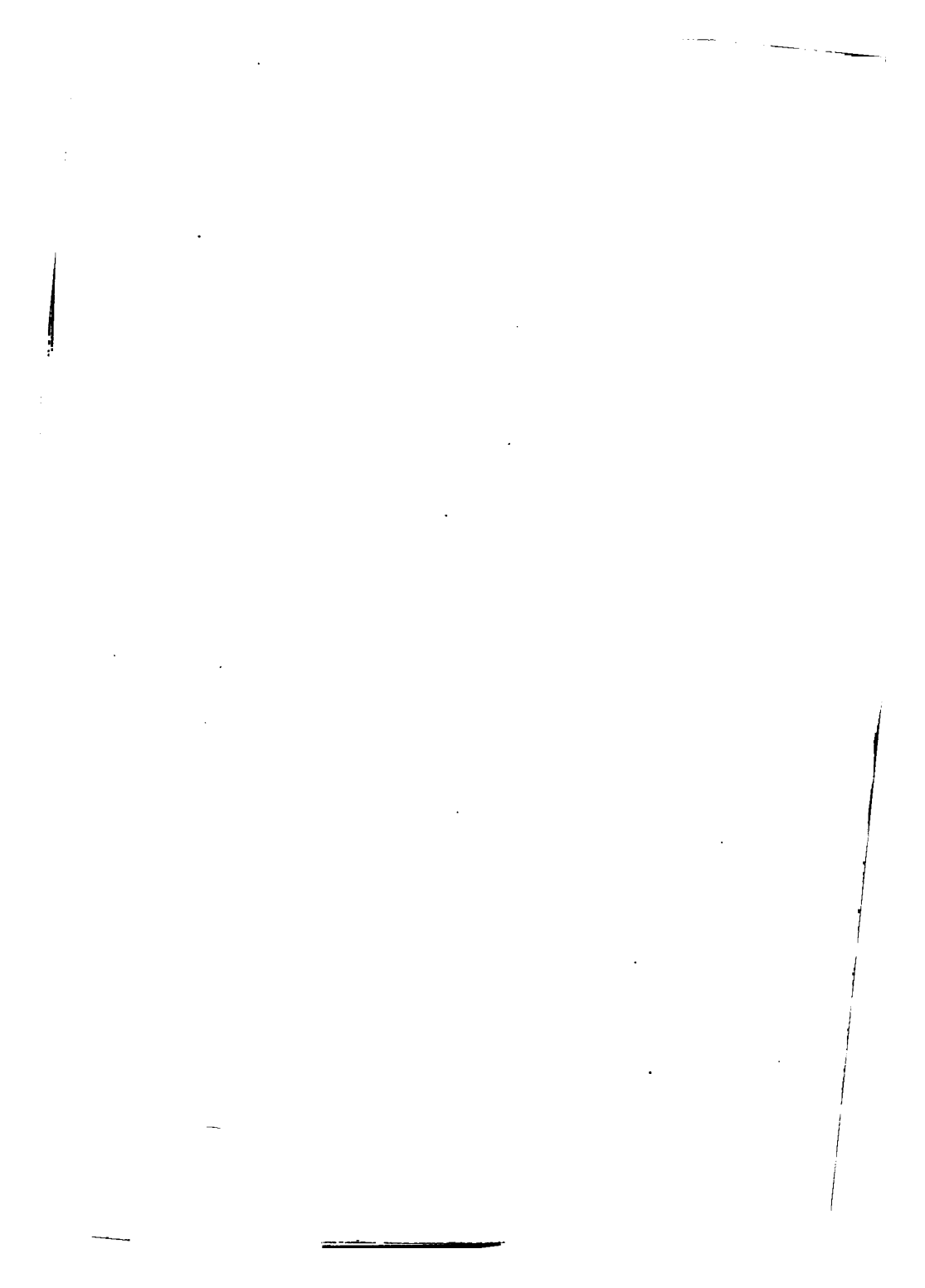


Fig. 21.—A Row of Remodelled Wood Pinion Cutters. Self-feeding

the foregoing machines, another form of machine has been also put in use, which embodies some of the features already noted, but which substitutes a different and improved form of automatic blank feed. These machines, by the employment of a large amount of oil, are able of working more rapidly than any heretofore used, and are also adapted to the cutting of wheels of all kinds, and will be considered in a subsequent chapter.



CHARLES VANDER WOERD. .



CHAPTER V.

In the last chapter we remarked upon the apparent crudity of many of the machines in early use in the original American watch factory. They were primitive, certainly; but the conditions under which they were made were of the same character, and the fact of such tools being made and used is not to be taken as evidence of a lack of inventive ability on the part of those who used them, but rather as showing an ability to accomplish desired results by the simple means to which a lack of capital restricted them.

The limited market for the early product of American watches, would of necessity forbid the expense of building special machines of restricted character or capabilities, and compel the use of appliances of limited cost, and of a nature adapting them to a variety of uses.

In this paper we will consider some of the numerous and successive forms of machines for the cutting of teeth in watch wheels of brass. The earliest of these, within the knowledge of the writer, was a machine for cutting train wheels, and was simply a small iron planer such as is used in machine shops, or by model makers.

It had the ordinary reciprocating bed, or table, which was moved back and forth by means of a hand crank, the connection probably being by the old-fashioned chain, such as was formerly used in the feeding of the



Fig. 22.—Webster Train Wheel Cutter, Improved.

carriages of engine lathes. On the cross head of this little planer was mounted a suitable frame which carried the fly cutter spindle, which was driven from above by belt in the ordinary manner. On the movable table was placed the head stock, whose index was operated by

hand. While this arrangement was somewhat crude, it served its purpose, and had its day. But in 1865 Mr. Ambrose Webster designed a new and excellent machine for train wheel cutting, with mechanism for automatically moving the carriage, and also for operating the index, (Fig. 22) which, in an improved condition, is shown in the accompanying view. The most serious fault in this machine was the manner of adjusting cutters for depth, which adjustment was effected by means of an eccentric quill, in which the cutter spindle was journaled. It would probably be a true statement of fact to assert that this machine has cut more millions of watch wheels than any other machine in the world, it having been in almost constant use for thirty years. Following this, and possessing several advantages over it, was one designed by the writer about 1872, which is shown in the next view. (Fig. 23.) As this machine was, at a later date, modified so as to adapt it to the cutting of steel wheels, we will defer further mention of it at this time, and consider some of the earlier forms of machines for brass wheel cutting.

The next illustration shows a machine with a history; more of history than will ever be written. It is doubtful if there is a person living who knows the



Fig. 23.—Marsh Train Wheel Cutter.

original form of this machine (Fig. 24,) or one who could accurately narrate the numerous changes, additions, and improvements which were made in it. Within the knowledge and recollection of the writer, this machine was used for cutting the teeth of minute



Fig. 24.—Old Minute Pinion and Hour Wheel Tooth Cutter.

pinions and hour wheels, and it would probably be safe to assume that it was originally designed for such use. The work was placed on an arbor at the top of the vertical quill spindle, shown in front, and held in place by a yoke which served as a sort of tail stock. The fly cutter was mounted in a short arbor or spindle, which revolved on centers, and also carried the belt

pulley. Reciprocal motion of the cutter was obtained by the vibration of a frame, which was mounted in suitable bearings on an adjustable carriage, which could be moved toward or from the stationary quill, for the purpose of adjustment to size. On this vibrating cutter-frame was mounted an adjustable arm which extended beyond its axis and terminated in a sort of toe, against which pressed a cam, which was mounted on a driving shaft; on one end of which shaft was a loose running clutch pulley, while on the opposite end was another cam, which, through a system of levers, slides, springs, and catches, performed the operations of unlatching and turning the index. It will be observed that the path of the cutter through the work, instead of being in a straight line, described a short arc of a circle. Of course such a motion involved a theoretical imperfection in work produced, but inasmuch as only a single thin wheel or pinion was cut at a time, the error was indistinguishable. This machine just failed of being automatic in action, for the mechanism always stopped before the last tooth was cut, but as the driving of the fly cutter was independent of the other movements, the operator was able to depress the swinging arm for the cutting of the last tooth. When in operation, this little machine produced an impression that something was being done,

for the combination of noises caused by the operation of the various slides, clicks and latches, mingling with the hum of the fly cutter, was quite unlike any other combination in the factory. But it accomplished a good deal of work, and if it were human we would give it a

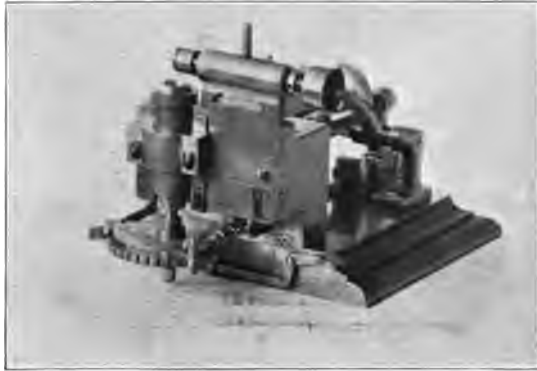


Fig. 25.—Improved Minute Pinion and Hour Wheel Tooth Cutter.

most respectful salute. The foregoing machine was some years since displaced by the machine shown in the next view (Fig, 25), which, while resembling its predecessor in the matter of the vertical index spindle, possesses no other similar feature. But it has one mechanical feature which, we believe, is novel in machines of this character, namely, the absence of all springs in the

mechanism for operating the index. These machines, of which several were used (and some of them are still in use), were very satisfactory in operation.

The cutting of minute pinions is now performed in

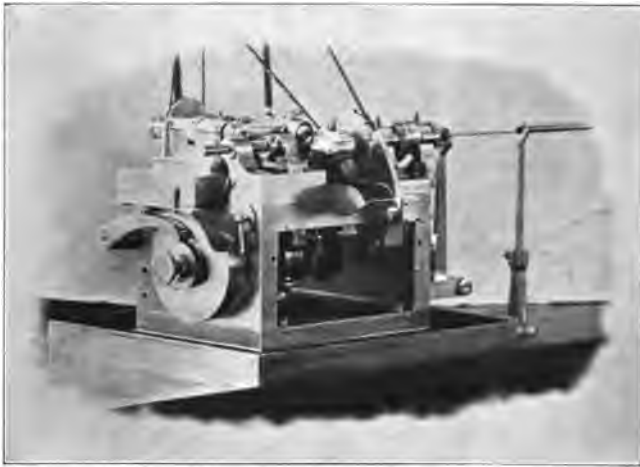
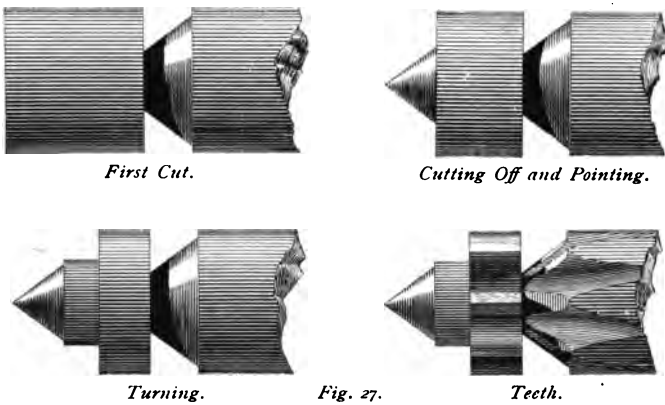


Fig. 26.—The Church Automatic Minute Pinion Cutter.

direct connection with the turning, and thereby insures axial truth. For this work an automatic machine was designed by Mr. D. H. Church, which is shown in the next view (Fig. 26). In this machine is placed a long rod of wire, which is acted upon by turning tools until a blank is formed in proper shape for cutting the teeth, the

turning tools then retire and a suitable fly cutter comes into action, the blank is indexed step by step, and when all the teeth are formed, the fly cutter moves away and a cutting-off tool moves forward and severs the completed



pinion. The accompanying diagrams will serve to indicate some of the successive operations (Fig. 27).

The proper cutting of the teeth of escape wheels is certainly a matter of great importance and of no little difficulty; the peculiar form of the teeth demanding the utmost accuracy in workmanship, and requiring a succession of cuts by as many different shaped cutters. It is probable that quite early in the experience of the Waltham factory it was found practicable to mount these

different cutter spindles in a single rotatable block or head, so that the several cutters could be brought into operative position as required. The writer is not pos-

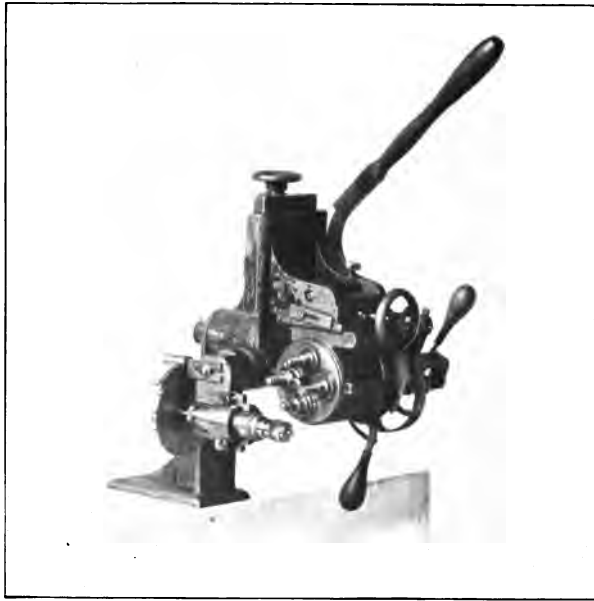


Fig. 28.—Old Escape Wheel Cutter.

itive as to the form of the machine first used for this purpose, but it is quite likely that the machine shown in the next view was at one time employed in that work (Fig. 28).

The late Ambrose Webster used to take considerable pride in saying that he made the first wheel tooth-cutting machine with automatic motions which was ever used in American watchmaking. But that machine was only

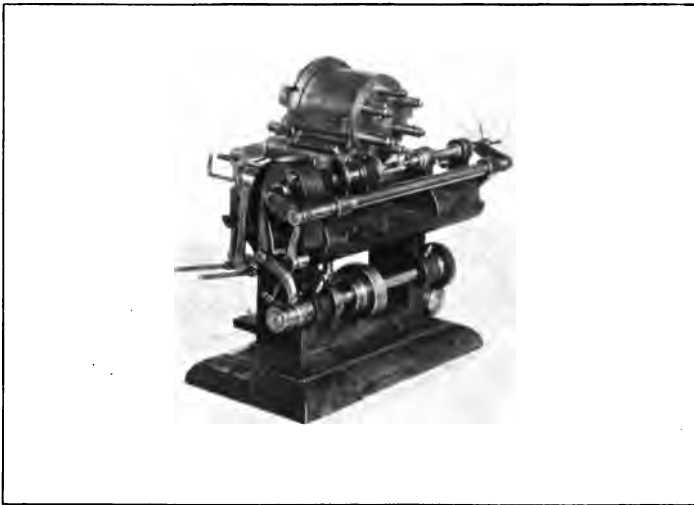


Fig. 29.—Webster Escape Wheel Tooth Cutter.

claimed to be semi-automatic. It was the machine shown in the accompanying illustration (Fig. 29), and was made for cutting the teeth of escape wheels, and was automatic to the extent of moving the carriage and operating the index, and also stopping itself on the

completion of the work of each of the six cutters required. The operator had then to bring the succeeding cutter into operative position and again start the machine. Some years later Mr. Vander Woerd constructed a machine of a different form for performing



Fig. 30.—Woerd Escape Wheel Tooth Cutter.

the same kind of work. This machine was automatic to about the same extent, and in the same features, as the Webster machine, but it omitted one motion which the Webster machine obtained, viz., the lifting of the cutter to avoid contact with the work during its return

movement. Mr. Woerd's machine is shown in the previous illustration. (Fig. 30.) To meet the requirements of the increasing product of the factory, and at the same time to reduce the cost of the work, the writer,

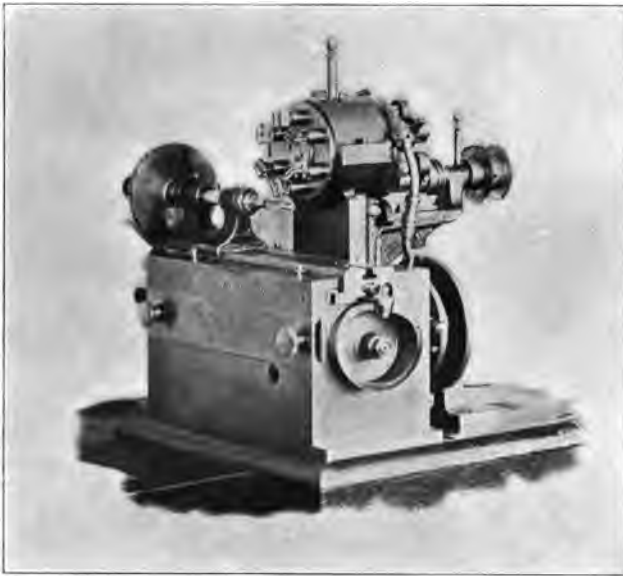


Fig. 31.—Marsh Escape Wheel Tooth Cutter.

about eleven years ago, designed another form of escape wheel cutting machine which extended the automatic features, so as to embrace all the movements of the machine, viz., the reciprocating movements of the

carriage, the lifting of the cutters during the return movement, the step by step motion of the index, the successive changes of cutters, and the stopping of the machine at the conclusion of the ninety cuts required. This machine is illustrated by Fig. 31.

CHAPTER VI.

All forms of machines for the cutting of the teeth of watch wheels doubtless possess certain features in common; but while this is true it is also true that there can be, and indeed is, a great variety in forms of construction, and a diversity of ways in producing the various mechanical movements required. In the simpler or more rudimentary forms of such machines only the driving of the cutting tool would be accomplished by power, leaving the movement of the work into contact with the cutter, and the shifting of the index wheel, to be performed by the hands of the individual operator. Such a form of construction, of course, restricts the attention and labor of the operator to a single machine; and the capacity or the faithfulness of the individual largely determines the productiveness of the machine. So long as a very limited product is desired a machine of the simple form above mentioned would not only answer the desired purpose, but would, doubtless, be the most economical form to use. With increased demands, however, the cheap machine would prove to be expensive to use. It is also true that up to a certain point it is good economy to

construct machines in such form as renders them capable of a variety of uses, thereby avoiding the expense of building a multiplicity of special machines which

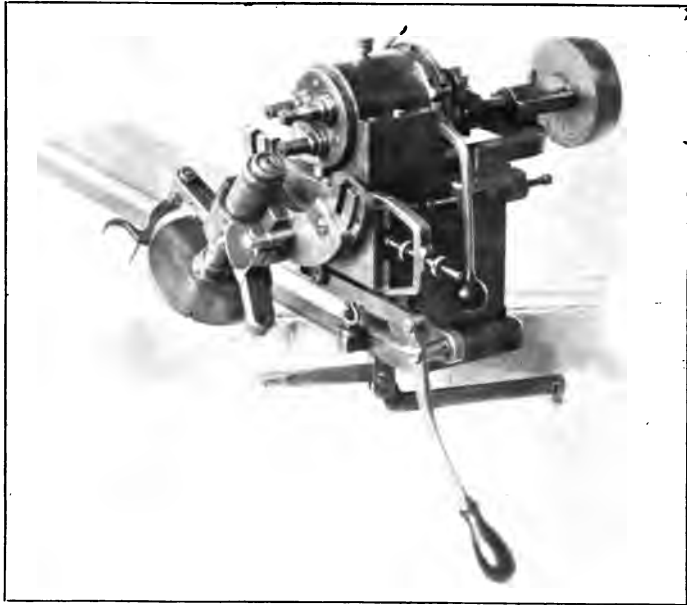


Fig. 32.—The Woerd Stem Wind Wheel Cutter.

might remain idle during quite a portion of the time.

The adoption of stem-winding mechanism in watches made needful the employment of steel wheels and pinions, many of them being of other than the ordinary

form of construction, and therefore complicating the matter of cutting the teeth. Experience, also, long ago demonstrated that it is not economical to attempt to remove with a single cutter all of the metal required to form finished wheel teeth. Saws are much cheaper to furnish than epicycloidal cutters, and will remove metal quite as easily. Therefore, in cutting steel wheels, a saw is used to remove a large portion of the metal, and this is followed by a forming cutter. The steel ratchet wheels, used on key-wind watches, whose shallow teeth could be formed without the removal of very much metal, were cut with a single mill or cutter, and that work could, therefore, be done with a simple machine, but when the American Watch Company commenced the manufacture of stem-winding watches, Mr. Vander Woerd constructed the form of machine shown in the accompanying illustration. (Fig 32.) This form of machine embodied two features which were of great convenience. They were, first, the incorporation of a plurality of cutters, the illustration shows three spindles, each carrying a cutter. The rear end of each of these spindles carried one member of a toothed clutch, which, when the spindle was brought into operative position, would engage the corresponding member which was carried by a running spindle or shaft. The disengaging

of the clutch and partial revolution of the spindle-carrying drum were performed by means of two hand levers (one of which is shown). A second feature which was of very great convenience, was the provision for holding the work at any desired angle relative to the line of cutting, so that any of the bevel wheels and pinions required for stem-winding watches could be cut. This form of machine, however, was in no sense automatic in any of its movements, but has proved to be a very convenient machine to have in the factory, because of its ready adaptability.

The first automatic machine for steel wheel cutting was designed by the writer, and, by some modifications has been adapted to a variety of other uses. In a simplified form it has been used for a number of years as a train wheel cutter, and was alluded to in the last chapter. In the form shown in the accompanying view (Fig. 33) which shows a group of three, arranged to be attended by a single operator, they are arranged to employ two cutters, the change from one to the other being automatic, as is also the movement of the work, the turning of the index, the lifting of the cutters during the return movement of the carriage, and the stopping of the machine on the completion of the work. For some classes of work it is desired, or required, to have the

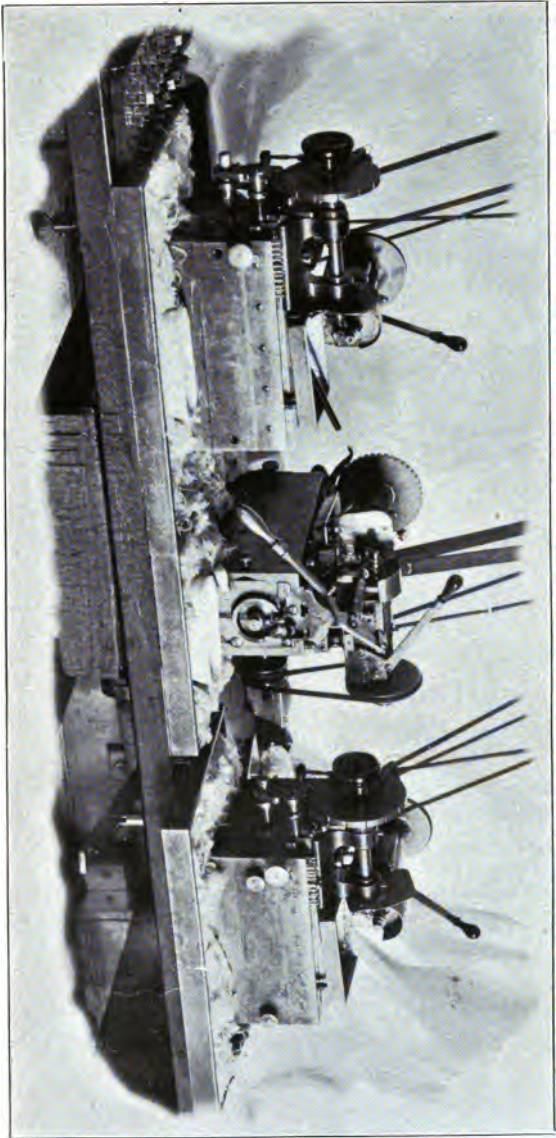


Fig. 33.—The Marsh Automatic Steel Wheel Cutters.

additional support of a tail stock, and one of these machines is shown as so provided. They, however, come short of being entirely automatic, in that they require the services of an attendant to supply the blanks and remove the completed work. Prominent in the stem-winding mechanism of the watch is the duplex or crown wheel, which wheel is in many cases provided with two sets of teeth, one of which is on the periphery and the other on the face, the latter meshing with the teeth of the winding pinion, and the former with the winding wheel. Sometimes the face teeth are located near the outer edge of the wheel so that the teeth are practically continuous with those on the periphery. It is not only possible but practicable in cutting the edge teeth of these wheels, to hold them in "stacks" on a suitable arbor, but of course in cutting the face teeth, only a single blank can be cut at a time; and great care is required to insure exact coincidence of the teeth on the face with those previously cut on the edge. The machines shown in the last two illustrations are adapted to the two classes of cutting required on crown wheels. But some years since the writer designed a machine in which both series of cutting should be performed simultaneously. The next illustration will indicate the nature and appearance of the machine (Fig. 34), which, it will



Fig. 34.—The Marsh Crown Wheel Cutter.

be seen, is in the favorite circular or continuous form, and may be briefly described as provided with four cutting spindles, each of which is adjustable in two directions. The first two of these are for cutting the face teeth, and the other two for the edge teeth. The first of each set carrying a saw, and the other two the forming or finishing cutters. These four spindles are mounted on double slides, and are suitably disposed around a central carriage or turret, which turret carries five vertical quills, in which are the work-carrying spindles; the wheel blanks to be cut being held by suitable chucks at the top, while the lower end of each spindle is provided with an index, which is accompanied with a holding latch and a suitable arm and pawl for the step by step movement of the index. It will be observed that while there are but *four cutter spindles* there are *five work holding spindles*. This fact allows the operator to place a blank in the chuck of the fifth spindle while the work of cutting is progressing on the other four, so that the work of the machine is continuous. After the blank has been secured in place, the turret turns one-fifth of a revolution, which carries the blank into position to be acted upon by the first cutter, which is in the form of a saw, and as the index is operated step by step, the saw passes down and out at the proper angle to the

face of the wheel, each movement removing a portion of metal, thereby blocking out the face teeth. In the meantime the operator places a blank on the second spindle. When all the face teeth in the first blank have been blocked out, the turret again makes a partial revolution, which carries the first blank to position to be acted upon by the finishing cutter, and the second blank to the position just vacated by the first. The third position is for the saw for the edge teeth, and the fourth is for the finish of the edge teeth. The next movement of the turret brings the finished wheel to its starting place, when it is removed and another blank put in its place. All the operations proceed simultaneously, so that a completed wheel which requires the four milling cuts, is produced during the time occupied by one operation, and inasmuch as the somewhat large number of teeth in the wheel necessitates a corresponding length of time for cutting, the operator is able to attend another machine also. The latest form of wheel cutter, which is shown in the next view (Fig. 35), is the invention of Mr. D. H. Church, and, by a suitable arrangement or combination of cams, can be adapted to the cutting of stacks of wheels (as shown in the cut), or to the cutting of single wheels on the face. This machine, by reason of its automatic feeding mechanism, requires no individual

operator, but allows him or her to attend to a large group of similar machines, which may be employed on



Fig. 35.—The Church Automatic Wheel Cutter.

a great variety of cutting. The use of a liberal amount of oil allows these machines to produce an unsurpassed amount of work.

CHAPTER VII.

It will be understood that in this work it is not intended to describe, nor even mention, all of the various machines used in the manufacture of watches, but rather to select a few types, and note the progress in their productiveness, which the growth of the business has demanded, and which has been a large factor in the reduction in manufacturing cost, and of which the great public has reaped the larger benefit.

Next to the plates, and the wheels and pinions, the numerous screws required may be regarded as prominent. We will, therefore, devote a short chapter to the consideration of some of the various forms of screw-making machines which have been in use in the American Waltham Watch Factory. The original threads, or rather, the threads used in the early Waltham watches are said to have been obtained from Swiss "jam plates," and when, in later years, definite pitches for all the sizes of screws were determined upon, they were established on the inch measurement, which system was in use in the factory previous to the adoption of the "metric system" which is now used. So that while the various

numbers of threads per inch were somewhat systematic (varying from 110 to 240 per inch) yet their equivalents in metric measurements *seem* not to be so systematic.

The early method of screw-making, consisted of the use of a small bench lathe, with the ordinary split chuck for holding the wire rods, which chucks were closed by means of the regular draw-in-spindle and hand wheel. On the lathe bed was a double slide rest with one tool for turning down the wire to form the body of the screw, and another tool for "cutting off." The lathe was also provided with a swing, or "tumble tail stock" containing two or more spindles, one of which served as a "stop" to regulate the length of the screw, another spindle carried the threading die. For turning the lathe during the threading process, the hand of the operator was employed, so that care was required in running on the die to avoid twisting off the slender screw when the die came in contact with the shoulder which formed the under side of the head. After the threading operation the cutting off tool was brought into action, and the wire rod partially severed. enough metal being left to sustain the screw. At this point the operator would pick up a "slotting plate," and holding it to the nearly severed screw, turn the lathe and run the screw into a tapped hole in the plate until it came in

contact with the head, when the severing process was completed by twisting it off. This method of screw-making in the Waltham factory was so long ago discarded, as to make it a matter of some difficulty to



Fig. 36. Early Form of Screw Cutting Lathe.

gather the material required for an illustration, but the accompanying view will serve to show what was at one time in use, (Fig. 36). Mention has been made of the "slotting plate;" in this view such a plate is shown leaning against the bed of the lathe. When all of the two rows of holes in the slotting plate had been filled with

screws in the manner above mentioned, it was fastened to the carriage of the slotting machine, which, on being started, would steadily carry one row of screw heads into contact with the running saw, the workman in the meantime taking another plate and continuing his work of turning, threading and cutting off. When the first row of screws were slotted, the carriage was drawn



Fig. 37.—Early Form of Screw Head Slotting Machine.

back to its former position, the plate removed and reversed, and the other row slotted as before. The plates were then taken by a boy who removed the slotted screws, and returned the plate to the workman for another filling. The next figure shows one of the above mentioned slotting machines (Fig. 37). The brass screws to be used in the rims of balances, while made in a similar, but not identical manner as that

just described, were taken off in a sort of block instead of the above mentioned slotting plate. The reason for this method being the readiness of releasing the slotted screws from the slotting block, or holder, which was desirable from the fact that the threads of balance screws are very fine and delicate, and therefore liable to



Fig. 38—Old Balance Screw Slotting Machine.

injury. This slotting block was circular in form, and consisted of two plates held together by a screw nut. The joint between the two plates was drilled with a row of radial holes, tapped to fit the balance screws, which were inserted, as made, in a manner similar to that already described. When this block was filled it was placed on the arbor or spindle of the special slotting machine shown in the next view, (Fig. 38), which also

shows the slotting block. On starting the machine the block was slowly revolved, carrying the heads of the radiating screws into contact with the slotting saw. When completed the block was removed from the machine, the clamping nut turned back to allow the two halves of the block to separate, when the screws would readily drop out.

The large number of screws required in watchmaking, when carried on to the extent which it had been for years at the Waltham factory, led to the attempt to improve upon the above described methods, and to Mr. C. V. Woerd belongs the credit of taking the first step in that direction. The next view (Fig. 39) shows the first Automatic Screw-making Machine. This was made in 1871, and has been in constant use ever since that time. This particular machine was designed for making "Jewel Screws," this screw doubtless being selected for two reasons; first, because of the large number used, and second, because being so very small, it would be more easily made by a machine. About four years of successful use of this machine led to the designing of a larger machine, substantially the same in principle, but adapted to the production of the larger watch screws. This heavier machine is shown in Fig. 40. Examination of this picture will show that a



Fig. 30.—Ward's First Automatic Screw-Making Machine.

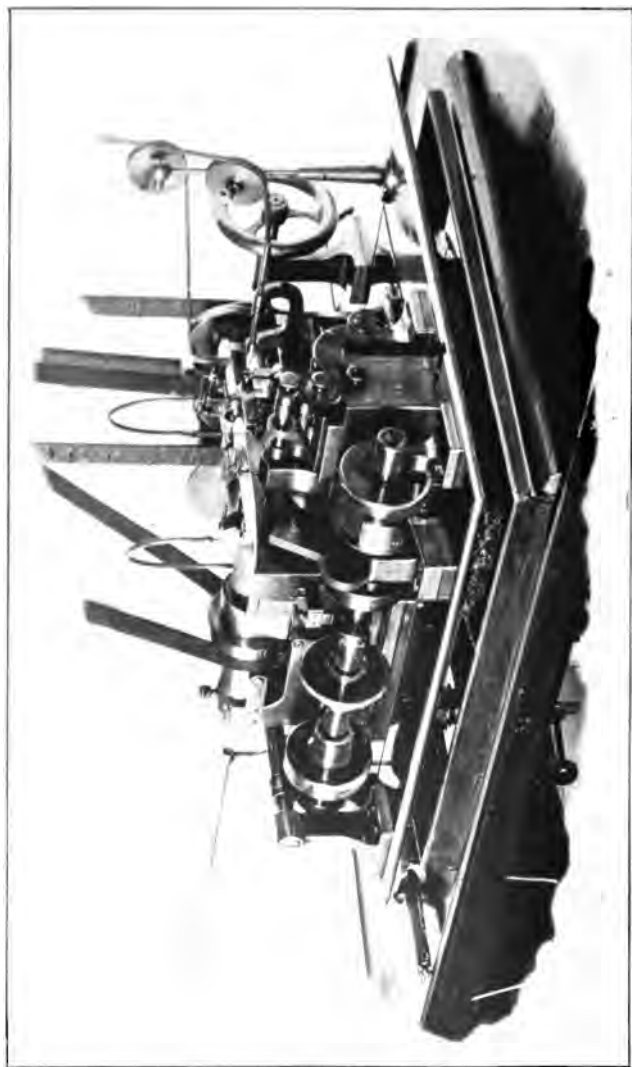


Fig. 40.—Second Automatic Screw-Making Machine, for Larger Screws.

machine of this kind must of necessity be expensive to build; and this fact led to the designing of a machine more compact in form as well as more simple, and therefore of cheaper construction. This latter form, which was designed by Mr. D. H. Church, possesses some features, besides cheapness, which are not found in the Woerd machine, and which enable it to perform some kinds of work which it would be difficult, if not impossible, to do on the older machines. The Church machine is shown in the next view (Fig. 41.)

In all the foregoing machines the various and requisite operations of loosening the chuck, feeding forward the wire rod, tightening the chuck, turning the body of the screw, cutting the thread, and severing the blank from the rod, are performed *successively*, while the slotting of the head could proceed during the time occupied by one or more of the other operations.

It was the conviction of the writer that a great economy would be secured by the adoption of a machine so designed that *all* of the above operations could proceed simultaneously. Such a machine was made, and has for ten years been employed in making the largest screws used in full plate watches, making pillar screws at the rate of twelve per minute. In a slightly modified form these machines are used for making balance screws,

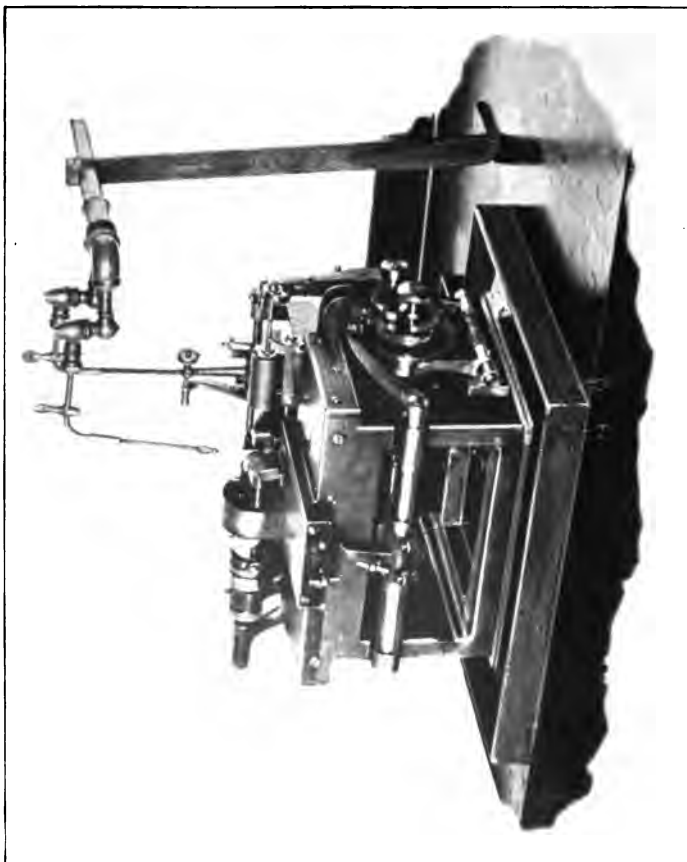


Fig. 41.—The Church Automatic Screw-Making Machine.

which, being of brass, are capable of more rapid production, so that twenty screws per minute are made on a single machine, (Fig. 42).

But a single operative can readily attend to six or more of any of the above mentioned forms of automatic machines, so that while by the older method a man might make 1,200 to 1,500 screws per day with a little aid from a boy, it is possible for one man alone with these machines to easily make 50,000 to 60,000 per day. This result is attained by the adoption of the automatic features, by which it is made possible for one person to attend to a number of machines, and also the arrangement of the machine which provides that all the successive operations involved in making the screws are carried on simultaneously. This latter fact is accomplished by the use of a multiplicity of spindles, each of which carries a rod of wire, and which successively present themselves to the various tools, in the favorite "procession," which continues until the rods of wire are exhausted, when the machine will stop until replenished.

But the turning, threading, cutting off and slotting of the screw does not complete it, for there remain the finishing operations, which involve much more of expense than attends the making operations. Formerly, it was

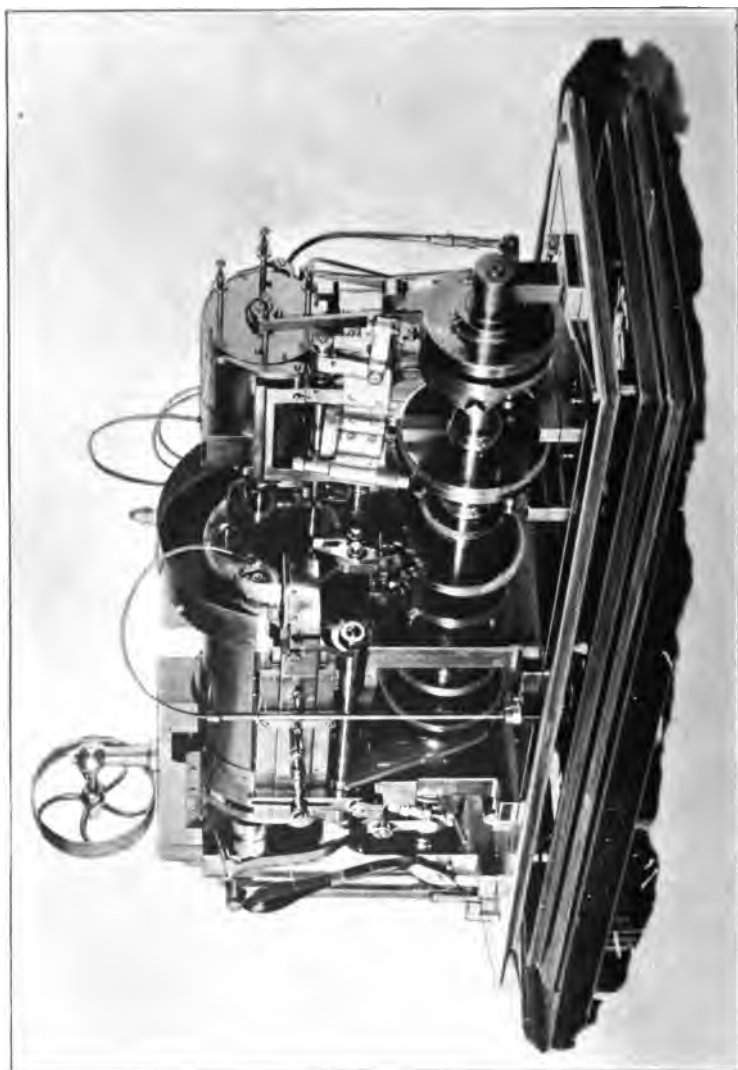


Fig. 42.—The Marsh Automatic Screw Making Machine.

needful to handle each individual screw as many times as there were distinct operations involved in the finishing process. But improved processes and machines have reduced the expense of finishing the heads to quite an extent.

The next view shows a lathe once used for finishing screw heads, (Fig. 43). The running spindle carried a



Fig. 43.—Old Screw Head Finishing Lathe.

chuck, whose center was threaded to receive the screw, which was held in the fingers of the operative, and when properly presented to the revolving chuck, it would be drawn in, till the screw head came in contact with the end of the chuck. The operative then applied the surface

of a fine oil stone to the head of the revolving screw, and moved it back and forth until the surface of the screw head was carefully ground; following this came a stick of boxwood whose surface was charged with Vienna lime and alcohol, a similar manipulation of this stick would produce the desired glossy surface. The operator then applied a suitable screw-driver to the slot of the screw head, and, by the left hand, turned

the lathe spindle backward, unscrewing the finished screw from the chuck. To insure the proper position of the above mentioned oil stone and stick, when in operation, a suitable rest was provided.

In the case of the brass balance screws, which must of necessity be entirely uniform, to insure poising, a double



Fig. 44.—Balance Screw Head Finishing Lathe.

rest was provided, and a file was also employed to bring the heads to the requisite length. In this machine (Fig. 44) an attachment was used for polishing the sides of the head as well as the end. The later practice is to grind and polish the ends in large numbers at a time, and for finishing the sides of the head, the machine shown in the next view was designed (Fig. 45). This will be recognized as one of the continuous running type of

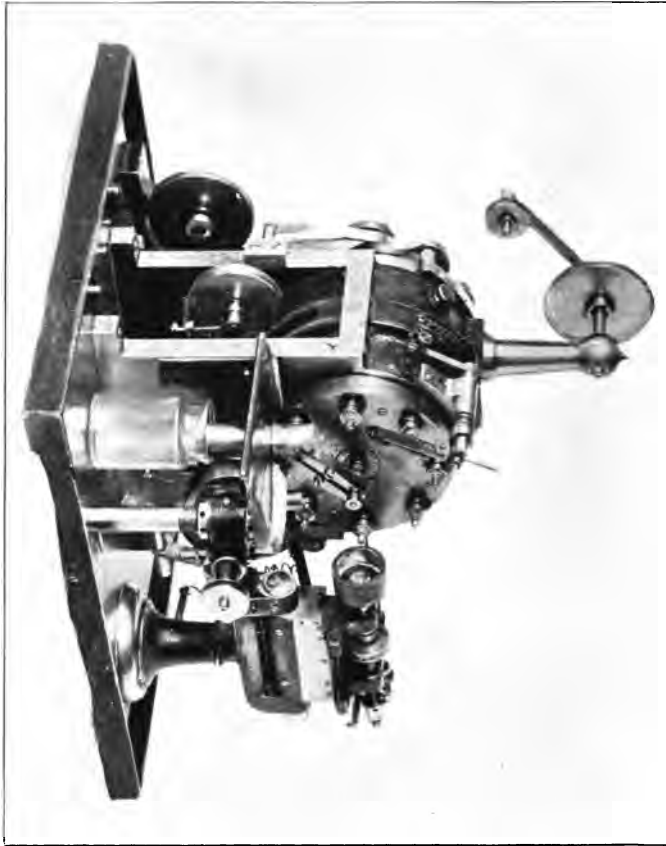


Fig. 45—Marsh Continuous Screw Head Finishing Machine.

machines previously mentioned. This machine has a revolving head, containing eight spindles, each of which is provided with an interior threaded chuck. The head revolves by a step by step movement, and the spindles, when they successively reach certain positions, are put in rapid motion.

When in one of these positions the operator presents the point of a screw to the chuck, and it is at once screwed in. That spindle then moves to another position, and in its progress passes under the action of a fine file, which removes any burr which may have been made by the slotting saw. At a later period the screw reaches a position to be acted upon by a swiftly revolving wood lap, which also has a vibrating motion. Another step or two carries the screw head to the action of a buff wheel, which gives additional gloss to the surface of the metal. At the next step the screw disappears, so that when the spindle reaches its first position the chuck is empty and ready for another screw; and so on. Another form of screw head finishing machine was originally made for finishing the minute screws used in holding jewel settings. Some girls acquire such skill in handling these screws that they could readily put them into the chucks of the running spindles, but it was entirely a matter of feeling.

A later form of machine has made this skill unnecessary, as each spindle, when it reaches the proper position, receives its screws automatically, or if it fails to

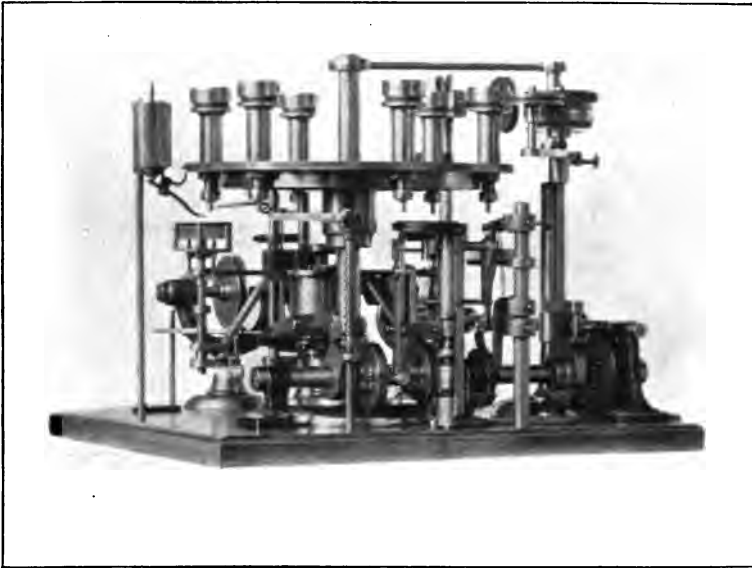


Fig. 46.—The Wood Machine for Finishing the Heads of Jewel Setting Screws.

do so, that failure stops the machine, and so avoids injury to the empty chuck by the action of the grinding and polishing mechanism. This machine (Fig. 46) is the invention of Mr. Gleason Wood. Other forms of

machines have been made for finishing round-topped heads, but this chapter is quite long enough, and we will not attempt any description of them.

CHAPTER VIII.

In the last chapter we very briefly described the machines for the making and finishing of the balance rim screws.

In this chapter we will review some of the machines which have been, or are now employed in the production of the balance itself. The making of the balance involves a larger number of successive operations than any other single piece of the watch movement. It also demands the utmost care in manufacture, to insure its absolute truth and reliability of action under the varying conditions to which it is subject when in the performance of its important and delicate work.

It is to be understood that we refer to the bi-metallic or expansion balance, (which is the only form of balance used by the American Watch Company) and that from the nature of its structure it is absolutely essential that it be as near perfect as possible in every particular. We are however to consider, not the balance itself, but the machines used in its production; we will begin with the operations required after the brass portion has been united to the steel body of the balance blank.

For the satisfactory action of the completed balance under varying temperatures, it is desired that the more expansive brass be made as dense as possible. This density is ordinarily secured by some sort of a compression process. Quite possibly this may at some time

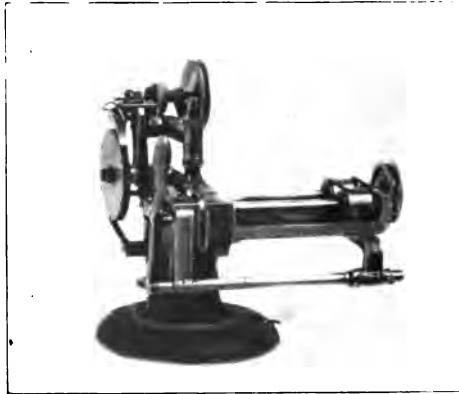


Fig. 47—Early Machine for Hammering Balance Brass.

have been accomplished by a long succession of blows by a hand hammer, if so, the operation must have been a tedious one, and probably not entirely satisfactory in its results.

The first mechanical means known to the writer for performing this work was in the form of a small trip hammer designed for this special use (Fig. 47.)

This machine was provided with two grooved rolls mounted on and near one end of two parallel shafts, which near their other extremities carried rolls of differ-



Fig. 48.—Another Early Machine for Compressing Balance Brass.

ent form. By means of two little belts one of these shafts was made to drive the other, the first one receiving its motion through a belt from a countershaft.

A count wheel was so arranged as to receive a step by step movement by means of an arm and pawl attached to the axis of the trip hammer.

The balance blank to be operated upon was held in position by a detached arbor which at one end was made slightly tapering and of such size as to fit the center hole of the balance. The other extremity of this arbor carried a role or disc of substantially the same diameter as the balance blank.

When in position the blank rested on the periphery of the two grooved rolls, and the disc rested in a similar manner on the two belted rolls at the other end of the parallel shafts; a suitable spring was arranged to maintain sufficient pressure to compel the motion of the two drive rolls to rotate the balance arbor. The balance blank being in position, the machine was put in motion and the feed rolls would slowly revolve the blank.

At every stroke of the hammer the pawl would move the count wheel a single tooth, and by means of a suitable stud attached to the wheel it would at a proper time lift a latch and release a shipper lever and stop the machine.

The object of this counting mechanism was to insure uniformity in the hammering of the rim, so that the

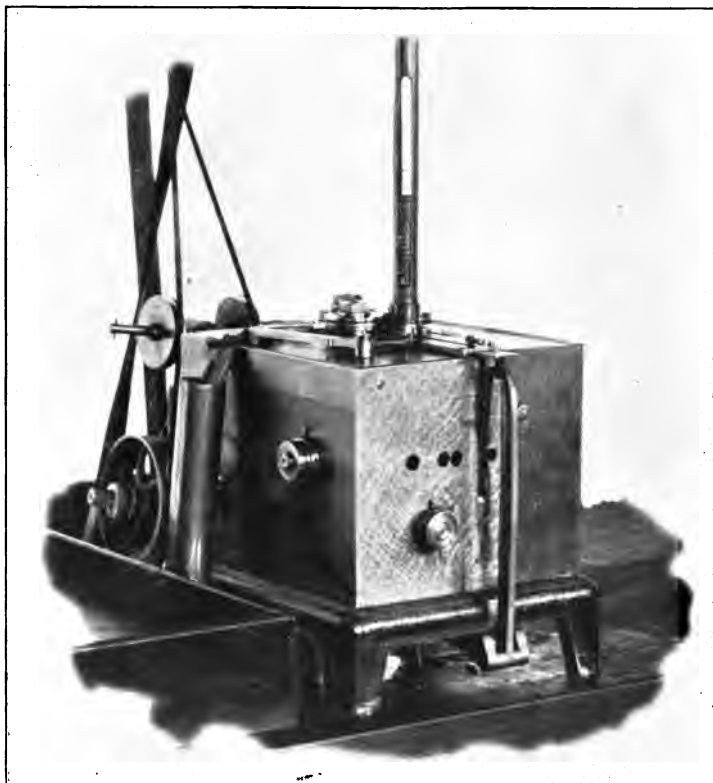


Fig. 49.—Self-Feeding Automatic Compressor for Balance Brass.

metal on the entire periphery of the balance blank should be of uniform density.

This form of machine was succeeded by the one shown in (Fig. 48) which, while more efficient in every way than the hammering machine, was displaced by the self-feeding and automatic acting machine shown in (Fig. 49.)

In this machine the blanks to be compressed are placed in the feed tube whence they are taken one by one from the bottom of the pile and carried forward and deposited on a suitable lifter which elevates the blank to a position where it can be grasped by the grooved rolls which gradually but relentlessly close in upon it, not "to squeeze the life out of it," but to give it a greater life. When the blank has been compressed to a definite size the rolls retreat and allow the compressed blank to drop, when it is pushed out of the way by a suitable arm, just in season to make way for another victim, which is "put through the mill" in the same manner.

This machine has only to be kept loaded with blanks and itself "does the rest."

The facing and recessing of the blanks then follow; and these operations were formerly done in ordinary bench lathes, each of which required an operative

(Fig. 50.) The later practice is to employ an automatic lathe, which takes the blanks from a loaded tube and automatically places them in the chuck, when the cutting tool advances and does its work and then retires,



Fig. 50.—Early Balance Facing and Recessing Machine.

when the chuck opens, the turned blank is ejected, and a new one received, and so on. The attendant, who can care for a number of machines, has for his principal work the sharpening and renewing of the cutting tools (Fig. 51.)

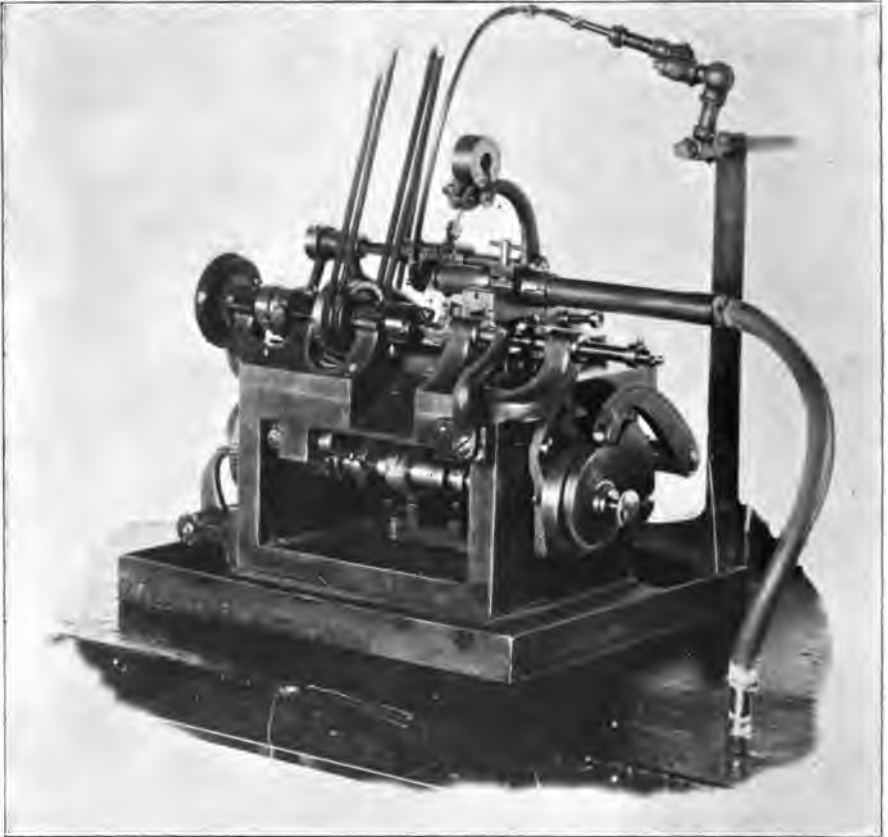


Fig. 51.—The Church Automatic Facing and Recessing Machine.

The blanks being turned and recessed, there follows the removal of two sections of the thin web of steel, leaving a transverse bar of metal, forming the arms of the wheel. As this bar is widest at the middle, tapering



Fig. 52.—Balance Webb Cutter.

on both sides towards the rim, the removal of the two sections of web is not so simple as it would otherwise be. Years ago it was the practice to make four cuts through the web with a suitable shaped mill which was sunk into one side.

The next operation was performed in a lathe, the spindle of which was given a reciprocating motion, and in connection with it a special crossing tool was made to cut through the web near the rim, thus completing the rim. (Fig. 52.)

The modern practice is to remove both sections of the web by means of a specially constructed punch and die.

The drilling and tapping of the numerous holes in the balance rim, for the reception of the adjustment screws, is unavoidably an operation of considerable extent, inasmuch as from fourteen to eighteen holes in each balance must be accurately located and carefully drilled and tapped at the proper stage of the work, and retapped when the balance is finished.

The earliest form of machine known to the writer for this drilling, consisted of a bench lathe with a swing tail stock containing a number of spindles, each carrying a special form of tool. In the running spindle of the head stock was a chuck, in which the balance was mounted, and provided with a transverse spindle, the outer end of which carried an index, graduated to correspond to the desired number and position of the holes in the balance.

The inner end of this little spindle carried a face plate to which the balance was clamped, and in such position

as to bring the desired location for a hole in the axial line of the lathe spindle. By having the chuck carefully counterbalanced it could be safely revolved at sufficiently high speed to drill the holes, etc. This lathe is shown in (Fig. 53.)

The transition from the slow and somewhat expensive



Fig. 53.—Early Balance Rim Drilling Machine.

method of drilling just described, to a method both rapid and correspondingly cheap, was in this case a radical one, omitting the steps of gradual progress which has marked improvements in most directions. Yet there was at least one preliminary step in a direction allied to these operations. The operation of tapping the numerous holes was

one of some delicacy and yet demanding rapidity in order to avoid undue expense; the speed was secured by mounting the tap in a small running spindle driven by power, but great watchfulness was demanded to avoid running the threading tap in too far, before reversing the direction of revolution.

The form of tapping machine shown in the next view



Fig. 54.—Early Balance Tapping Machine.

(Fig. 54), was therefore designed, which insured both speed and safety, inasmuch as it was arranged to give the tap a yielding pressure when entering the hole, and also allowed only a definite number of forward revolutions.

This tapping device was incorporated by Mr. C. V. Woerd into an automatic drilling machine, in the form shown in the next view (Fig. 55), and being automatic,

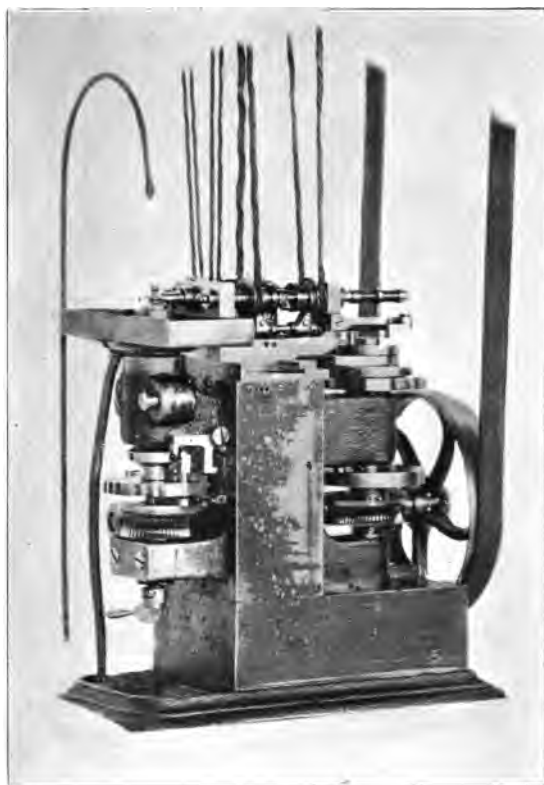


Fig. 55.—Woerd's Automatic Balance Drilling Machine.

save only in the supplying and removing of the balance, two persons are able to attend to twelve machines or more, which are arranged in close order.



Fig. 56.—Marsh Modern Balance Tapping Machine

For the final tapping of the holes, the machine shown in the next view has proved to be most excellent, as the entire number of holes are tapped simultaneously (Fig.

56). The finish turning and glossing of the balance rim is an operation demanding special care and accuracy, absolute truth and accuracy in diameter being required. The earlier practice was to bed the balance in cement on

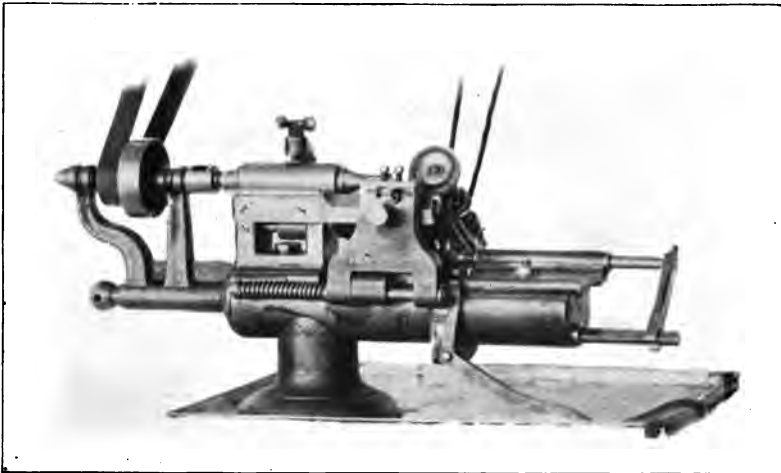


Fig. 57.—Finish Turning and Glossing Machine.

chuck, which was provided with true running arbor or pin. As the cement required to be softened by heat, both when securing the balance to the chuck, and when removing it after being turned, considerable time was necessarily consumed in securing the balance and getting it in readiness for the turning operations. At one time

the turning tools were in removable holders, which were taken in succession by the workman, and laid on a hardened tool-rest, in front of the work, and carefully passed over the running balance, each tool removing a small

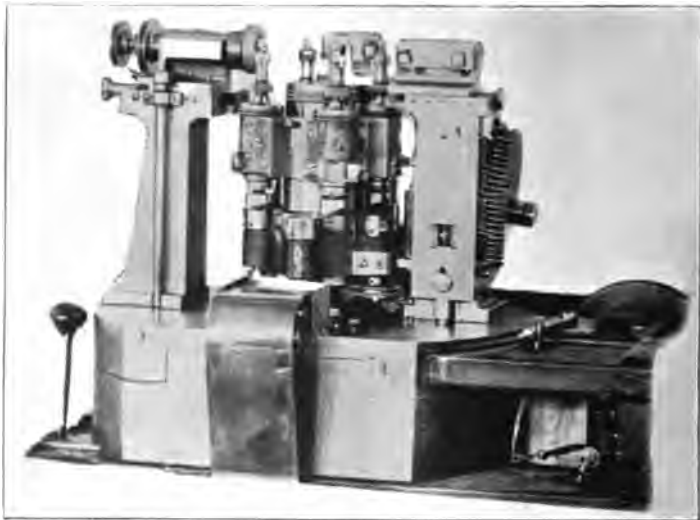


Fig. 58.—Marsh Modern Finish Turning and Glossing Machine.

portion of the metal. A later form of machine, or rather a modification of the foregoing machine, is shown in the next view (Fig. 57). This shows the turning tools mounted in a holder which is arranged to swing on an arbor, and also to slide on the same arbor, the holder

resting on a suitable guide; the movement of the slide being imparted through a suitable hand lever.

The illustration also shows the revolving polishing disc, for giving the finishing gloss to the rim.

This form of machine has been superseded by the one shown in the next view (Fig. 58), which is another application of the "procession" idea.

This machine is arranged with a turret carrying four running spindles, each of which at its upper end carries a specially made chuck for holding the balances to be turned. Suitably disposed around this turret are three tool rests, two of which are provided with turning tools, while the third carries a revolving polishing disc. This arrangement allows of the simultaneous performance of the two turning operations, and also of the polishing, while the fourth spindle is receiving a fresh balance, which will duly follow the others step by step around the circle, each spindle when arriving at the starting position bringing with it a completed balance; which the attendant will remove and supply its place with a fresh one. This arrangement enables one man to accomplish at least two and one-half times as much as by the previous method.





E. A. MARSH.



CHAPTER IX.

In the last chapter we reviewed some of the special machines used in the manufacture of balances; and it may not be inappropriate at this time to consider the companion of the balance—the hairspring, and its stud and pins.

It is probable that hairsprings are made in the same general way, by all makers, while the tools and machines employed in any one factory may be, and doubtless are, entirely dissimilar in form to those used for a like purpose in other factories. Of these various tools we can make mention of but few, and of them it will not be possible to illustrate the successive forms or steps in the long process of evolution.

We believe that there was a period in the history of this factory when hairsprings were purchased, instead of being manufactured. At a later period the finished wire was purchased, from which the springs were made. But about twenty-five years ago a machine for forming the wire was built. Subsequent modifications and improvements have resulted in the production of the machines shown in Fig. 59. These machines are so far

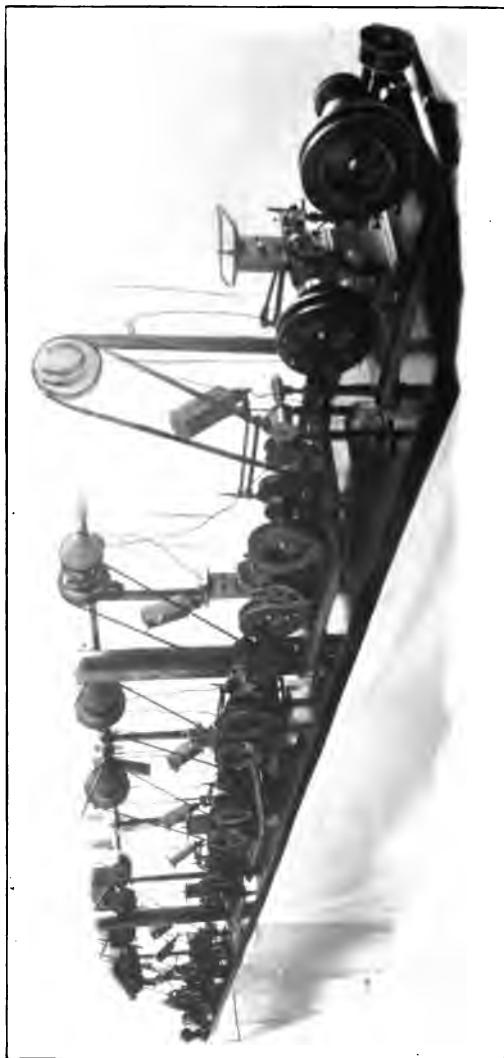


Fig. 50.-- Modern Automatic Hat Spring Wire Forming Machine.

automatic in operation that one man only is required to keep them busy. The character of the work done by the several machines is modified by the successive requirements of the wire, and include the drawing of the round wire to the exact diameter desired, then flattening of the wire by repeated rollings, and lastly by repeated and careful drawings through the finishing dies, by which the exact dimensions desired are obtained, together with the smooth and glossy surface which is indispensable to the production of a highly finished and bright colored spring.

The coiling of hairsprings seems to belong among the class of mechanical operations, or manipulations, which are not susceptible of marked improvement. There may be obtained a measure of superiority in the quality of the tools employed, but the processes of production admit of little variation. One exception may be made to the foregoing statement, it being the method of forming the overcoil of Breguet springs, which method was devised by the late John Logan, and by which it is possible to so form and confine the over-coil that it can be tempered complete, not requiring the careful and somewhat tedious manipulation otherwise demanded. The round hair-spring stud is one of the small parts of a watch movement, and quite simple in form as compared with the

older pattern, which was a long wedge like a piece of steel which was attached to the watch plate by a screw and two steady pins, and projected toward the spring like a balance cock. But, although quite simple in form, the diminutive size of the round stud makes it an incon-

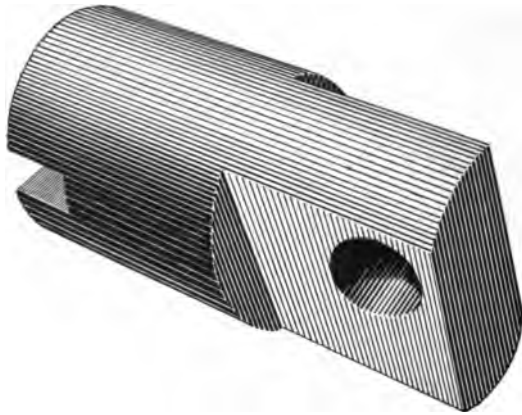


Fig. 60.—Form and Relative Dimensions of Hair Spring Stud. About Twenty-five Times Actual Size.

venient piece to manufacture—at least this was true during the early years of its production. The accompanying diagram (Fig. 60) will serve to indicate the form and relative dimensions of the studs, the largest of which are less than $\frac{4}{100}$ of an inch in diameter, by about $\frac{9}{100}$ of an inch in length, and at one end is flattened on two sides so as to form a sort of tongue, near

one corner of which is drilled a hole to receive the outer end of the hairspring. The opposite end of the stud is provided with a slit to receive a screwdriver. At one time it was the practice to cut off from a rod of wire, pieces of suitable length for one stud each. Then followed the operation of milling one of the ends, and finishing the other to the proper length. Next came the drilling of the hole for the spring. It is essential that this hole should be at an exact right angle to the axis of the stud, but with so little of total length, as compared to its diameter, it proved a very difficult piece to hold during the drilling operation, so that when inspected a large number were discarded for imperfections. But all that is a thing of the past. A special form of continuous running automatic machine, shown in Fig. 61, now does the work of milling the two sides, drilling and broaching the hole, and cutting to exact length, and producing a stud every six seconds. This is another instance of the efficiency of the "procession," or continuous running system.

The writer was once told by Mr. Chas. W. Fogg, the Patentee of the Safety Pinion, that when in his youth he was an apprentice to learn the watchmaking trade; on one occasion the boss was to be absent the whole day; he therefore told the young apprentice that he might

employ himself making hairspring pins. "Well, how many shall I make?" "O, make about a pint." Hair-spring pins are not bulky articles, and filing them by

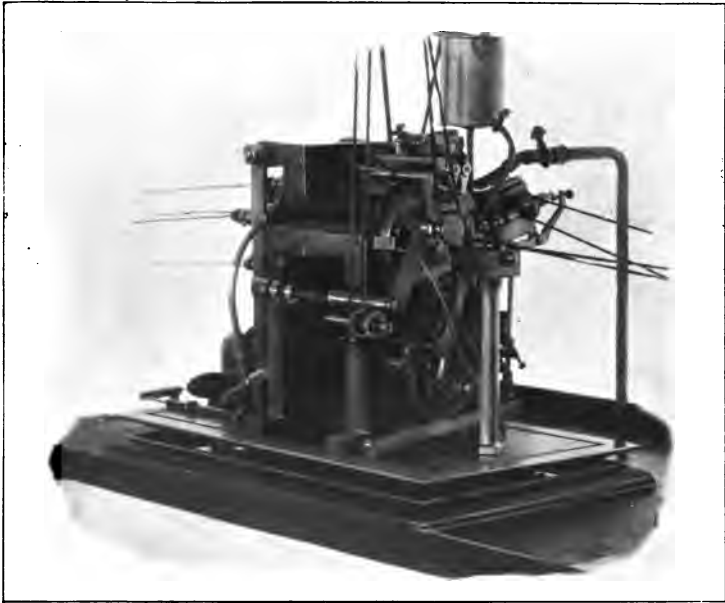


Fig. 61.—Marsh Automatic Hair Spring Stud Machine.

hand on wire held in a pin vise, twirled by thumb and finger, is not rapid work, but that was the *old* way. An improvement was made when the wire was held in a

spring chuck which was in a spindle removably connected with a spindle driven by a belt. With this was also employed a rotary file, as a substitute for, and improvement upon, the common hand file. This method, while probably producing better and more uniform pins than the primitive method, was by no means rapid, inasmuch as it was required to remove the inner spindle from the outer driving spindle, and after cutting off the completed pin, to loosen the chuck and pull out the wire to a distance required for another pin. Only a few inches in length of wire could be handled in this machine. But for several years past automatic machines of the form shown in Fig. 62 have been used. These take pieces of wire about 30 feet long, and produce pins at the rate of 20 to 35 per minute, according to the material used.

The proper adaptation of the hairsprings to the balances of watches is an indispensable requisite in the obtaining of a correct time rate. It is a matter of absolute exactness, and therefore one demanding special care and accurate tests. Until within comparatively a few years this work was done by the "cut and try" method, that is, by repeated trials of different springs, until one was found which would meet the requirements of each individual balance. The testing or trial could not be an



Fig. 6a.—Marsh Automatic Hair Spring Stud Pin Machine.

instantaneous matter, and often involved many changes; but in the case of the ordinary flat hair springs admitted of such latitude as could be corrected by "taking up" or "letting out" the spring.

Extended and careful tests have demonstrated that the correct action of a Breguet hair spring demands that the

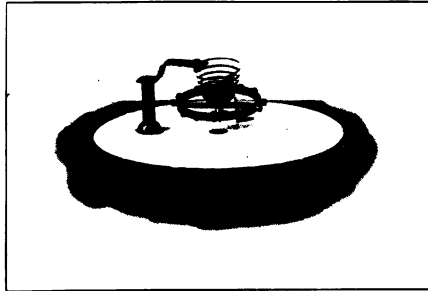


Fig. 63.—Device for Testing Balances and Springs.

stud be applied at a certain point in the overcoil, and that only a very slight deviation from this position can be allowed without destroying the proper action of the spring.

The late John Logan, who was extensively known as a maker of hair springs, was for several years employed as a "watch springer," and gave a great deal of thought to the problem of cheapening the cost of his work. As

a result of his thought and study, he invented a system of testing all hair springs by a standard balance, and all balances by a standard spring, and grading the springs according to their relative strength, and, by means of a long studied and carefully prepared schedule, or table,

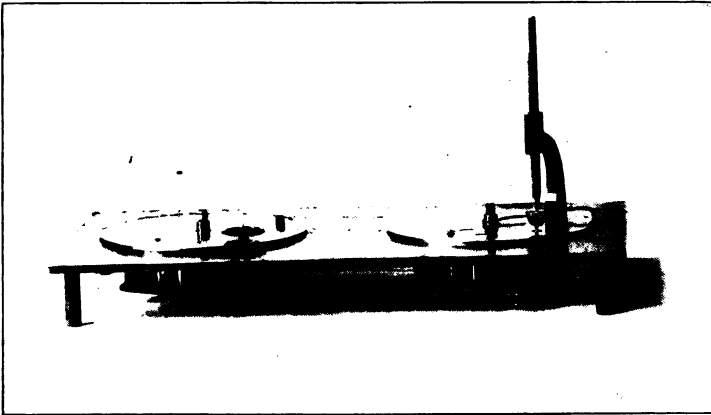


Fig. 64.—Logan Device for Testing Balances and Springs.

selecting the springs adapted to the various balances. This scheme was the occasion of a long and expensive lawsuit, resulting in favor of Mr. Logan. Some of the various devices for testing balances and springs are shown in the accompanying illustrations, Figs. 63 and 64.

Mr. E. J. Hall devised and patented the little comparators shown in Figs. 65 and 66, which are of value to a

certain extent, but their use demands an amount of keen and accurate perception which not every workman possesses.

Fig. 67 shows a special form of balances, or weighing



Fig. 65.—The Hall Patent Comparator.

scales, by which the “avoirdupois” of the complete watch balance could be determined. This was devised by Mr. Thomas Gill, who also designed the very ingenious and useful gauge shown in Fig. 68 for weighing the

relative strength of springs. By the use of these two devices, an *approximate* selection of springs, as to their adaption to balances could be made. This system, while helpful to a limited extent, was far from perfect, as it was manifest that while the *total mass* of each of a large number of balances might be exactly equal in weight to that



Fig. 66.—Another Hall Patent Comparator.

of each of the others, yet the metal might be so disposed as to give vibrational weight in some cases much greater than in others. So that the only accurate means for ascertaining the effective weight of balances is by vibration. The same method is also required to measure the strength of hair springs with the accuracy required. Such careful and minute gauging of necessity demands

that the determining vibrations shall be continued through an interval sufficiently prolonged to disclose or reveal the peculiar condition of each individual balance or spring.

To do this work thoroughly without entailing a large

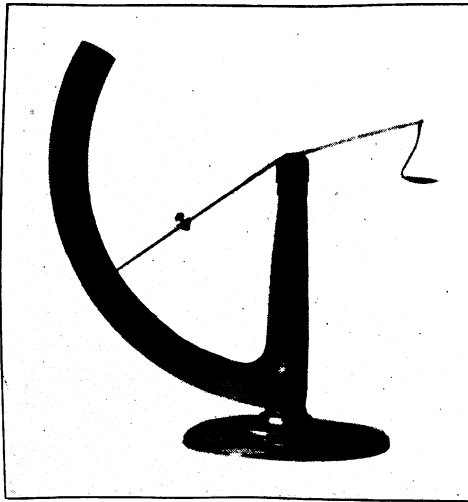


Fig. 67.—The Gill Scale for Weighing Balances.

additional expense, a form of special machine was devised, which has proved to be very efficient and reliable. Fig. 69 shows a number of these machines as arranged for use, some of them fitted for vibrating balances, others for springs, and still others for testing. By

means of this system the springs and balances are selected entirely independent of the movements to which they have been assigned, so that they do not come together until they reach the hands of the finisher.

In closing this series of papers, which have extended far beyond the original intention of the writer, it is



Fig. 68.—The Gill Gauge for Determining the Relative Strength of Hair Springs.

proper to say once more that it is impossible to convey more than a general idea of the direction and nature of improvement in machinery for watchmaking, and to indicate some of the steps in which progress has been made. The list of improved machines is by no means complete. No mention whatever has been made of



Fig. 60.—Balance and Hair Spring Vibrating Machines.



some of the most recent changes. At no time in the history of this company have changes been so numerous nor so radical as within the past two years. Enough, however, has been written to show that very great changes in manufacturing methods have been in progress during almost the entire existence of this factory. Many of the earlier methods and machines now seem crude; possibly they were known to be such at that time, but it is difficult for us at this day and in the light of recent mechanical achievements to realize the primitive conditions of forty years ago.

Perhaps no one of the past two score years has failed to witness some degree of improvement in machinery. Doubtless succeeding years will also bring additional changes, but it is not probable that the future student of the history of watchmaking will be able to discern in any like period as much of progress as will mark the last decade of the present century.

We have aimed to write of methods and machines, and not of men. But it seems proper in these closing words to make mention of two who are deservedly prominent; the first as being to a certain extent a pioneer in the field of designing and building watchmaking machinery, and the second who has by his fertility and originality in the field of invention, achieved so much in the embodiment

of automatic features as render his recent machines wonders of mechanism. We refer to Mr. C. S. Moseley and Mr. D. H. Church.

